



**Boise Cascade**  
*Engineered Wood Products*

# Simple Framing System®

A Technical Guide for  
Floor & Roof Framing  
Construction

## TABLE OF CONTENTS

|   |                   |
|---|-------------------|
| <b>The SIMPLE FRAMING SYSTEM®</b> .....                 | <b>2</b>          |
| <b>Boise Cascade and the Building Regulations</b> ..... | <b>3</b>          |
| <b>Boise Cascade and the Environment</b> .....          | <b>4</b>          |
| <b>Features and Benefits</b> .....                      | <b>5</b>          |
| <b>Lifetime Guarantee</b> .....                         | <b>5</b>          |
| <b>Product Profiles</b> .....                           | <b>6 - 7</b>      |
| <b>Design Support: BC CALC®, BC FRAMER®</b> .....       | <b>8</b>          |
| <b>BCI® Joist Specifications</b> .....                  | <b>9</b>          |
| <b>BCI® Joists — Design Properties</b> .....            | <b>10 - 11</b>    |
| BCI® Joists Used as Joists / Beams .....                | 10                |
| BCI® Joists Used as Rim Joists / Bearers .....          | 11                |
| BCI® Joists Used as Columns / Studs .....               | 11                |
| BCI® Joists Used as Ties .....                          | 11                |
| Allowable Nail Spacings .....                           | 11                |
| <b>BCI® Joists — Floor Applications</b> .....           | <b>12 - 35</b>    |
| About Floor Performance .....                           | 12                |
| Floor Design Criteria .....                             | 13                |
| Residential Floor Span Tables .....                     | 14                |
| Floor Framing Details Overview .....                    | 15                |
| Floor Details .....                                     | 16 - 24           |
| Framing Around Stair Openings .....                     | 25 - 26           |
| Load Bearing External Cantilever Details .....          | 26                |
| Temporary Construction Bracing .....                    | 27                |
| Hole Location and Sizing .....                          | 28                |
| Ground Floor Construction .....                         | 29                |
| Fire, Sound and Air Leakage Solutions .....             | 30 - 35           |
| <b>BCI® Joists — Roof Applications</b> .....            | <b>36 - 43</b>    |
| Roof Design Criteria .....                              | 36                |
| Roof Rafter Span Tables – 400mm centres .....           | 37                |
| Roof Rafter Span Tables – 600mm centres .....           | 38                |
| Roof Framing Details Overview .....                     | 39                |
| Roof Details .....                                      | 40 - 43           |
| <b>VERSA-LAM® Products</b> .....                        | <b>44 - 51</b>    |
| Introduction to VERSA-LAM® Products .....               | 44                |
| VERSA-LAM® Beam Specifications .....                    | 44                |
| VERSA-LAM® Design Properties .....                      | 45                |
| VERSA-LAM® Holes and Notches .....                      | 45                |
| Allowable Nail Spacings .....                           | 46                |
| VERSA-LAM® Used as Beams .....                          | 46                |
| Allowable Loads on VERSA-LAM® Beams .....               | 47                |
| VERSA-LAM® Used as Columns .....                        | 48                |
| Common Framing Details .....                            | 48                |
| Multiple Member Connectors .....                        | 49                |
| VERSA-LAM® Products .....                               | 50                |
| Used as Rim Material .....                              | 50                |
| Used as Rim Joists / Bearers .....                      | 50                |
| Concentrated Load Capacities of                         |                   |
| Boise Cascade Rim Products .....                        | 51                |
| BCI® Joists Used as Wall Studs .....                    | 52                |
| Metalwork Connectors .....                              | 53                |
| <b>Glossary</b> .....                                   | <b>54</b>         |
| <b>Helpful Hints</b> .....                              | <b>55</b>         |
| <b>Contact Information</b> .....                        | <b>Back Cover</b> |

## WELCOME AND INTRODUCTION

Thank you for your interest in our company and products.

This document is the UK Technical Guide for the SIMPLE FRAMING SYSTEM® range of engineered wood products.

This version, updated as of the date listed on the cover, contains information applicable for the use of our products when designed in accordance with BS5268 Part 2 2002.

A version will be released during 2012 that will provide similar information for the use of our products when designed in accordance with EC5.

Please ensure reference to the correct information during this transition stage in the UK building codes.

## ABOUT BOISE CASCADE

Boise Cascade, L.L.C. is one of the world's largest producers of engineered wood products and a leading wholesale distributor of building materials in the United States. We are privately owned with headquarters in Boise, Idaho. Please visit [www.bc.com](http://www.bc.com) for more information.

Boise Cascade founded its UK office in 1972 and has remained active in the market ever since.

In 1999 the company introduced its SIMPLE FRAMING SYSTEM® range of engineered wood products to the UK and today a network of Authorised Distributors throughout the UK and Ireland use this class-leading system to provide a wide variety of specifiers, builders and developers with competitive floor and roof solutions for use in domestic and commercial applications.

With support offices in Chirk, Wrexham and Alton, Hampshire; the SIMPLE FRAMING SYSTEM® is a complete package providing:

- ✓ Assured product provision and supply chain logistics
- ✓ Environmental procurement
- ✓ Regulatory authority product compliance
- ✓ CAD software
- ✓ Training
- ✓ Design & technical support

## BCI® Joist Floors and Meeting the Requirements of the Building Regulations

In the UK, all building products need to meet the requirements of the Building Regulations relevant to both the products and their intended use within a building. BCI® Joists used in floor construction need to meet the requirements of Part A (structure), Part B (fire), Part E (sound) and Part L1 (air leakage).

Boise's engineered wood products have been assessed by the leading UK building material approval authorities including the British Board of Agreement and TRADA. For BCI® Joists these include BBA Certificate 99/3620 and TRADA Q Certificate Number 036/007. VERSA-LAM® has been granted BBA Certificate 99/3619. Such certification is crucial for demonstrating the products compliance with Part A of the Building Regulations. Further information on the structural properties of these products are detailed on the following pages of this guide:

### Pages

BCI® Joists . . . . .9, 10 & 11

VERSA-LAM® . . . . .44, 45, 47, 48, 50 & 51

It is appropriate to consider the means of meeting the requirements of Parts B, E, and L1 of the Building Regulations simultaneously, to ensure that the floor solution meets all the requirements in an efficient and cost effective way. Details of the means by which BCI® Joist floor construction meets these requirements are given on the following pages:

### Pages

BCI® Joists - Fire, Sound, and Air Leakage . . . . . 30 - 35



Sound testing for Part E requirements.





Boise Cascade relies on natural resources - air, water, energy, and trees – to make and distribute the wood products people use every day. We operate in ways that sustain these natural resources and protect the environment today and for generations to come. We believe good business and good environmental practices go hand-in-hand.

Boise Cascade has a solid record of responsible environmental commitment and performance, including:

- **protecting air and water quality** near our manufacturing sites
- **responsibly using energy and wood resources**
- **reducing, reusing, and recycling** manufacturing and finished product waste materials
- **collaborating** with others by listening to and acting on constructive ideas to demonstrate our commitment

Our performance gives substance to our commitments.

### Protecting air and water quality

Making the wood products our society needs and wants requires processes that affect air and water near our manufacturing sites. Boise Cascade's dedicated employees have established a strong track record of protecting air quality near our production sites and rigorously cleaning the water (effluent) used in manufacturing whenever it is returned to nearby rivers. Our manufacturing operations consistently meet or exceed tough standards set by multiple and complex state and federal environmental regulations.

#### *For example:*

Our wood products manufacturing facilities have reduced smog-producing volatile organic compound emissions from green wood-drying operations by about 81% since 2000.

### Responsibly using energy and wood resources

Our manufacturing operations require substantial energy and wood resources. In addition to helping protect the environment, wisely using these resources is in our company's best economic interest. Efficiently and responsibly using energy and wood resources keeps our operating costs lower and ensures that we sustain the natural resources essential to our business. This underlying economic link makes our commitment to environmental health and sustainability a natural priority for us.

#### *For example:*

- Boise Cascade operations have reduced greenhouse gas emissions by about 5% since 2000. We joined the Environmental Protection Agency's voluntary Climate Leaders initiative in 2005; as a result we are committed to further greenhouse gas reductions.
- Boise Cascade is committed to sustainable forestry practices. Although we don't own timberlands, we carry independent third-party certifications as a procurer of wood fibre, as a producer of forest products, and as a purchaser of wood building materials. We don't purchase wood from old-growth forests. Our wood procurement practices are audited and certified annually under the Sustainable Forestry Initiative®, or SFI®; and the Programme for Endorsement of Forest Certification, or PEFC.

- Our engineered wood products are made using about half the wood fiber contained in traditional dimension lumber, resulting in superior products that more efficiently use natural raw materials.
- We track our wood fiber sources to ensure that the raw material and finished products we purchase meet our rigorous environmental standards.

### Reducing, reusing, and recycling

Effectively reducing and reusing waste in manufacturing processes and recycling material reduces the need for "virgin" (i.e., never-before-used) raw materials, a goal that often makes both environmental and economic sense.

The challenge is to eliminate as much waste as possible while productively reusing the waste that cannot be eliminated, thereby reducing our costs and the amount of material sent to landfills. Processes can be changed to more efficiently use raw materials, thereby reducing the byproducts left over as waste. Products can be engineered to use manufacturing waste and waste from finished products – wood, paper, plastics, etc.

#### *For example:*

- Boise Cascade's wood products plants are designed to use almost all the wood purchased as raw material. Wood that is not manufactured into I-Joists or laminated beams typically ends up in plywood or chipped and shipped to paper mills as raw material for their products. Sawdust and plytrim is either used in particleboard or burned for fuel. Bark is either burned on-site in boilers or veneer drying system, sold for fuel at other mills or sold for landscape materials. Most of the ash generated from burning of wood fuels ends up as an agricultural soil amendment. Very little of the original raw material ends up in a landfill.
- Boise Cascade works with our customers to reduce waste. Our engineered wood products are sold through Authorised Distributors trained in design and material management to ensure optimum yield from the stock lengths. Our BC Frammer software provides efficient designs and our BC Tracker provides fast optimising to ensure minimum waste. Large users combining these software packages with our SawTek™ cutting systems can see waste down to below 1%.

### Collaborating

At Boise Cascade, we reach out to stakeholders to get opinions and feedback on our environmental practices. We listen to and act upon constructive ideas to demonstrate our commitment and improve our environmental performance. We believe it's important for us to listen to and collaborate with others.

#### *For example:*

- Boise Cascade has joined the Climate Leader Partnership, a voluntary effort with the Environmental Protection Agency to reduce greenhouse gas emissions by setting aggressive reduction goals and reporting our results.

| Feature                        | Benefit   |
|--------------------------------|---|
| Laminated Veneer Lumber (LVL)  | Stable, strong and reliable engineered wood product that will not shrink, twist, cup, or bow like solid timber.   |
| Tight manufacturing tolerances | Accurate product sizes for installation into service class 1 & 2 environments. No shrinkage - no squeaks.   |
| Wide range of products         | Competitive and compatible solutions.   |
| Clean appearance               | Inspires product confidence for the builder, inspector, and home buyer.   |
| Stiff and strong               | Quiet, flat floors – even ceilings. No herringbone strutting / blocking required at the mid span.   |
| Light in weight                | Easy to handle.   |
| Eased edges                    | Reduces potential splinter injuries.  |
| Pre-stamped knock out holes    | Easy access for wiring and plumbing.  |
| High performance OSB web       | Accommodates holes for larger services if necessary in accordance with guidelines detailed in this technical guide.   |
| BC CALC® and BC FRAMER®        | Computer-aided design. Full supporting calculations and layout drawings.  |
| Full layout drawings           | Easy-to-read, job-specific joist layout plans.  |
| Precise component packages     | Easy to install, no waste.  |
| Installation guide             | Easy-to-read installation instructions.   |
| Technical guide                | Comprehensive technical details.  |
| Technical support team         | Expert help is on hand.   |
| Site trimming                  | Easy to cut on site using basic hand tools.   |
| Materially efficient           | Wise use of natural resources. The peeling process in the manufacture of LVL is a very efficient use of round log raw materials. The BCI® Joist is a very efficient structural shape. |
| Quality assured – BBA approved | Clean, consistent, reliable products.   |
| Lifetime guarantee             | Instills confidence in the products and the construction.   |



**Lifetime Guaranteed Quality and Performance**

Boise Cascade warrants its BCI® Joist, VERSA-LAM®, and ALLJOIST® products to comply with our specifications, to be free from defects in material and workmanship, and to meet or exceed our performance specifications for the normal and expected life of the structure when correctly stored, installed and used according to our Installation Guide.





## BCI® Joists

A world leader in high quality engineered wood products, Boise Cascade Engineered Wood Products offers a wide range of BCI® Joists.

BCI® Joists are manufactured to precise specifications using VERSA-LAM® laminated veneer lumber flanges bonded to an orientated strand board (OSB) web.

The use of VERSA-LAM® as the flange material avoids the inherent problems that plague solid timber such as shrinking, twisting, cupping, and bowing, all of which contribute to squeaking floors.

Light in weight, yet immensely strong, the long-length BCI® Joists are quick and easy to install. Delivered to site in precise precut component packages, the SIMPLE FRAMING SYSTEM® dramatically reduces installation times and the potential for error.

Straight and true, BCI® Joists create flat floors and even ceilings. Pre-stamped holes in the OSB web allows speedy installation of wiring and plumbing. Other holes can be made in the web to accommodate larger services.



## VERSA-LAM®

VERSA-LAM® provides the foundation for the SIMPLE FRAMING SYSTEM®.

Manufactured by bonding high-specification rotary-peeled timber veneers to create huge billets of engineered wood, VERSA-LAM® is one of the strongest and most reliable engineered wood products available in the UK today.

Available in a wide range of sizes, VERSA-LAM® is an excellent partner for BCI® Joists in the SIMPLE FRAMING SYSTEM® and can also be used for a variety of purposes including floor and roof beams, lintels, purlins, columns, studs, door stock, and more.

VERSA-LAM® is popular amongst timber frame designers and manufacturers with a range of sizes suitable for timber frame as well as masonry construction.

Boise Cascade strives to lead the world in new veneer technology. Our Product Development Team continuously researches new veneer species and bonding techniques to further push the boundaries of engineered wood products.







## VERSA-LAM® as Rim

VERSA-LAM® is available in a 38mm width for use as a high grade rim board in timber frame applications. It can also be used as a stairwell closure and in certain beam applications.

VERSA-LAM® has been specially developed to withstand high compressive stresses perpendicular to the grain. This makes it ideal as a rimboard in timber frame construction to transmit the vertical loads from load-bearing walls through the floor construction to the load-bearing walls below.

The use of VERSA-LAM® can reduce the need for squash blocks in high load applications.

VERSA-LAM® is available in a range of depths to suit the other components in the SIMPLE FRAMING SYSTEM®.



## VERSA-STRAND® as Rim

VERSA-STRAND® rim board is available in 32mm and 38mm widths for use as a high grade rim board in timber frame applications.

VERSA-STRAND® has been specially developed with one of the world's leading OSB manufacturers to a proprietary code evaluated formula. The alternating orientation of the strands provides both vertical load and horizontal shear capacity making it ideal as a rim board in timber frame construction to transmit the vertical loads from load-bearing walls through the floor construction to the load-bearing walls below whilst providing racking resistance to the floor joist structure.

VERSA-STRAND® is a highly cost effective alternative to LSL / LVL in rim applications.



## BC CALC® Software

BC CALC® performs engineering analysis to help our customers size beams and I-joists for their building projects. It is simple to use, yet flexible enough to analyze most joist and beam applications. The user enters span, load, and hole information, and the program analyzes which of Boise Cascade's engineered wood products are necessary for a project.

After the analysis has been run, the user may print an easy-to-read design report that clearly shows span and load information as well as analysis results. The program includes a comprehensive Help menu.

BC CALC® is available for download to designers, architects, and engineers free of charge.

Please visit <http://www.bc.com/wood/ewp/software/bccalc.html>

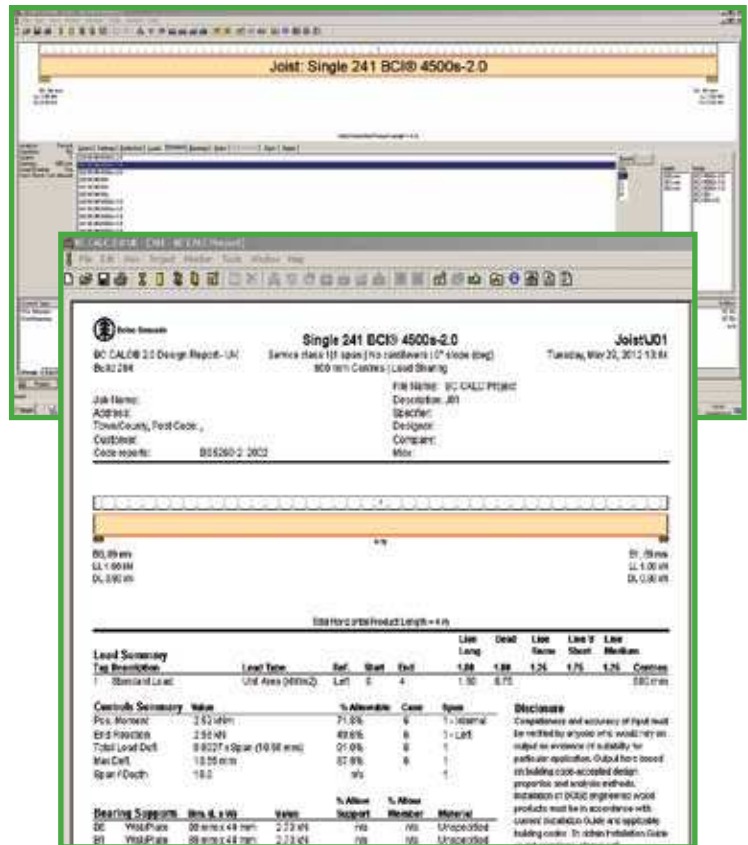

## BC FRAMER® Software

BC FRAMER® helps our Authorised Distributors create floor and roof framing layouts quickly. This easy-to-use computer-aided 3D drafting program frames layouts and creates piece and price reports. It also draws framing drawings that use Boise Cascade's engineered wood products and develops schedules. BC FRAMER's editing and drawing tools allow flexibility when modifying framing layouts. The software also allows the user to customise the layout drawing with framing details, notes, symbols, and accessories.

For more information, call Boise Cascade EWP Engineering on 01420 590078.

### TECHNICAL SPECS

This program is designed to work on stand-alone computers.

- Current Pentium Processor
  - 4GB RAM (min.)
  - Microsoft® Intellimouse
  - 1024x768 or higher display
  - Microsoft® Windows 7 or XP Professional
- Improvements in capacity or speed of these components will yield better performance.

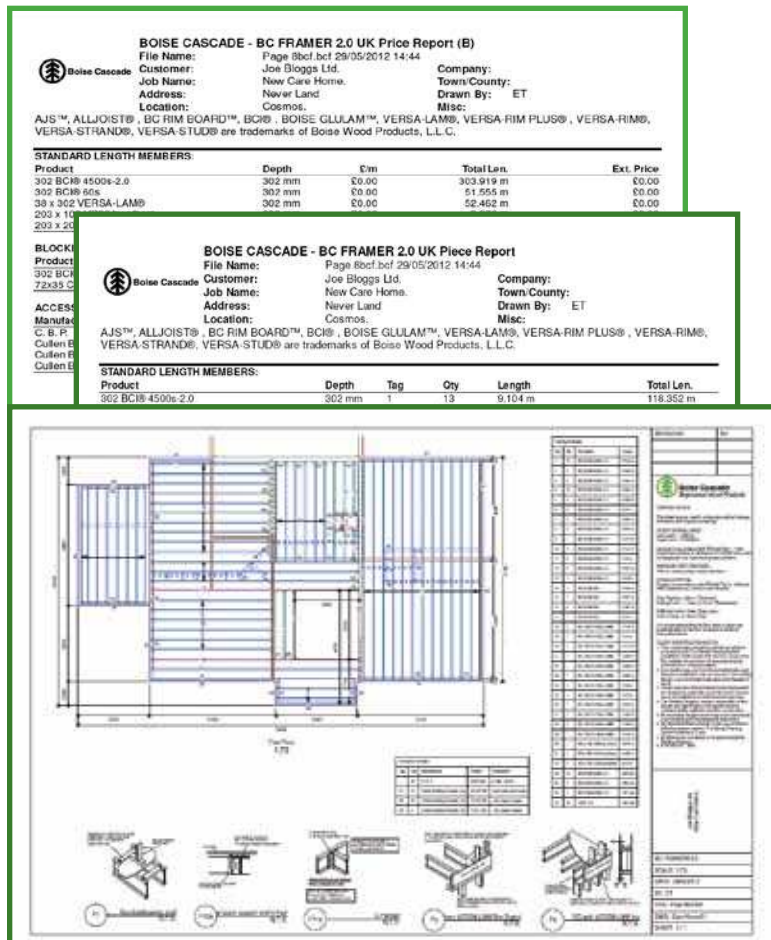



## BCI® 4500s

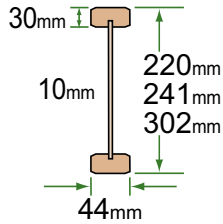

## BCI® 6000s

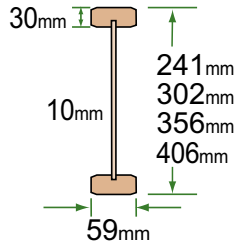

## BCI® 60s

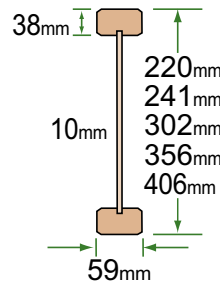

## BCI® 90s

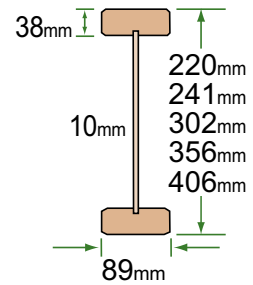

## BCI® Joist Specifications

### Materials and Manufacture

BCI® Joists are manufactured with VERSA-LAM® LVL flanges, orientated strand board (OSB) webs and waterproof structural adhesives. The OSB web sections are glued together at 1220mm centres to form a continuous web. The webs are glued into a 12mm deep groove in the centre of the wide face of the flange members. All components are machine-assembled and pressed in one continuous operation. Boise Cascade operates the two of the largest and fastest I-joist plants in the world.

### Quality Assurance

BCI® Joists are approved for use in the UK by the British Board of Agrément and are manufactured under a factory production control system audited on a monthly basis by a third-party inspection agency.

### Sizes

Four joist series, BCI® 4500s, 6000s, 60s and 90s, are available. Each joist is available in a range of depths as detailed in the product profile illustration above. Joists are manufactured up to 20m long.

### Tolerances

The tolerances (in mm) on member sizes are:

|                        |                |
|------------------------|----------------|
| Joist length .....     | ±3.2           |
| Joist height .....     | ±0.76          |
| Flange thickness ..... | ±1.27          |
| Flange width .....     | -0.51 to +0.38 |

### Moisture Content

BCI® Joists will arrive on-site with a moisture content of 8% to 10%. In a service class 1 environment (as defined in BS5268-2:2002), BCI® Joists will remain at an equilibrium moisture content of approximately 10%, whilst in a service class 2 environment, they will absorb a little moisture from the atmosphere and attain a final equilibrium moisture content of 12% to 14%.

*NOTE: The corresponding equilibrium moisture contents of solid timber in service classes 1 and 2 will be approximately 12% and 18%, respectively, having typically been delivered to site at a moisture content of 18% to 24%.*

### Preservative Treatment

BCI® Joists are untreated products with a natural durability sufficient to ensure a minimum design life of 60 years when installed in a service class 1 or 2 environment and not subject to mechanical damage or insect attack. Differences in the swelling characteristics of the materials used in BCI® Joists mean that preservative treatment should not be undertaken without consulting Boise Cascade Engineered Wood Products as this may affect the structural integrity of the component.



**BCI® Joists are approved for use under the UK Building Regulations by British Board of Agrément BBA Certificate No. 99/3620.**

**BBA certification is recognised by:**

N.H.B.C.                      TRA  
 UKTFA                        Building Control Officers  
 Building Contractors



**Engineered Wood Products**

Certificate Number 036/007

BCI® Joists are intended for use as structural members such as floor or roof joists, beams, rafters, wall studs or ceiling ties, in service class 1 or 2 environments as defined in BS5268-2:2002.

Design properties for BCI® Joists in these internal conditions are given in the table below for long-term loading. Design properties for shorter load durations may be determined by applying the appropriate value of the  $K_3$  modification factor given in BS5268-2:2002.

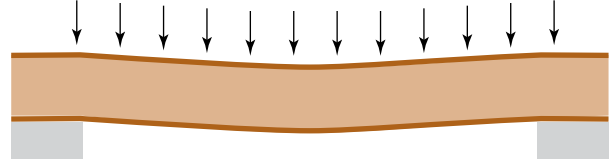

## BCI® Joists Used as Joists / Beams

| Long-Term Design Properties of BCI® Joists in Bending ( $K_3 = 1.0$ ) <sup>1, 2</sup> |                  |                               |                  |              |  |              |                  |                       |                  |                |                   |                |                  |                |                            |                |                  |              |                  |       |       |       |       |
|---|------------------|-------------------------------|------------------|--------------|--|--------------|------------------|-----------------------|------------------|----------------|-------------------|----------------|------------------|----------------|----------------------------|----------------|------------------|--------------|------------------|-------|-------|-------|-------|
| Service Class 1 Conditions — (20°C / 65% rh)  |                  |                               |                  |              |  |              |                  |                       |                  |                |                   |                |                  |                |                            |                |                  |              |                  |       |       |       |       |
| Joist Depth   | Joist Type       | Bending Moment Capacity (kNm) |                  |              | Flexural Rigidity (EI) (Nmm <sup>2</sup> x 10 <sup>9</sup> ) |              |                  | Shear Resistance (kN) |                  |                | End Reaction (kN) |                |                  |                | Intermediate Reaction (kN) |                |                  |              |                  |       |       |       |       |
|   |                  | Load Sharing                  | Non-Load Sharing | Load Sharing | Non-Load Sharing   | Load Sharing | Non-Load Sharing | Load Sharing          | Non-Load Sharing | 45mm Bearing   |                   | 89mm Bearing   |                  | 89mm Bearing   |                            | 133mm Bearing  |                  |              |                  |       |       |       |       |
|   |                  |                               |                  |              |  |              |                  |                       |                  | Web Stiffeners |                   | Web Stiffeners |                  | Web Stiffeners |                            | Web Stiffeners |                  |              |                  |       |       |       |       |
|   |                  | No                            | Yes              | No           | Yes  | No           | Yes              | No                    | Yes              | No             | Yes               | No             | Yes              | No             | Yes                        | No             | Yes              | No           | Yes              | No    | Yes   |       |       |
| Load Sharing  | Non-Load Sharing | Load Sharing                  | Non-Load Sharing | Load Sharing | Non-Load Sharing   | Load Sharing | Non-Load Sharing | Load Sharing          | Non-Load Sharing | Load Sharing   | Non-Load Sharing  | Load Sharing   | Non-Load Sharing | Load Sharing   | Non-Load Sharing           | Load Sharing   | Non-Load Sharing | Load Sharing | Non-Load Sharing |       |       |       |       |
| 220   | 4500s 2.0        | 3.18                          | 3.06             | 348          | 4.61   | 4.43         | 1.68             | 3.73                  | 4.47             | 3.59           | 4.30              | 5.20           | 5.96             | 5.00           | 5.73                       | 8.93           | 8.93             | 8.59         | 8.59             | 8.93  | 8.93  | 8.59  | 8.59  |
|   | 60s 2.0          | 5.12                          | 4.92             | 536          | 4.75   | 4.57         | 1.88             | 4.34                  | 5.10             | 4.17           | 4.90              | 5.81           | 6.56             | 5.59           | 6.31                       | 11.63          | 11.73            | 11.18        | 11.28            | 11.63 | 11.73 | 11.18 | 11.28 |
|   | 90s 2.0          | 7.86                          | 7.56             | 820          | 4.75   | 4.57         | 1.95             | 4.34                  | 5.10             | 4.17           | 4.90              | 5.81           | 6.56             | 5.59           | 6.31                       | 11.63          | 12.38            | 11.18        | 11.90            | 11.63 | 12.38 | 11.18 | 11.90 |
| 241   | 4500s 2.0        | 3.52                          | 3.38             | 429          | 4.99   | 4.80         | 1.81             | 3.73                  | 4.47             | 3.59           | 4.30              | 5.20           | 5.96             | 5.00           | 5.73                       | 8.93           | 8.93             | 8.59         | 8.59             | 8.93  | 8.93  | 8.59  | 8.59  |
|   | 6000s 1.8        | 4.11                          | 3.95             | 498          | 6.01   | 5.78         | 1.82             | 4.59                  | 5.04             | 4.41           | 4.85              | 5.25           | 5.56             | 5.05           | 5.35                       | 10.06          | 10.52            | 9.67         | 10.12            | 10.06 | 10.52 | 9.67  | 10.12 |
|   | 60s 2.0          | 5.70                          | 5.48             | 645          | 5.39   | 5.39         | 1.75             | 4.15                  | 4.86             | 4.15           | 4.86              | 5.12           | 5.39             | 5.12           | 5.39                       | 9.19           | 10.17            | 9.19         | 10.17            | 10.80 | 10.95 | 10.80 | 10.95 |
| 302   | 4500s 2.0        | 4.51                          | 4.34             | 718          | 6.12   | 5.88         | 2.22             | 3.73                  | 4.47             | 3.59           | 4.30              | 5.20           | 6.33             | 5.00           | 6.09                       | 8.93           | 8.93             | 8.59         | 8.59             | 8.93  | 8.93  | 8.59  | 8.59  |
|   | 6000s 1.8        | 5.26                          | 5.06             | 832          | 7.05   | 6.78         | 2.25             | 4.76                  | 5.55             | 4.58           | 5.34              | 5.54           | 6.52             | 5.33           | 6.27                       | 10.02          | 10.70            | 9.63         | 10.29            | 10.02 | 10.70 | 9.63  | 10.29 |
|   | 60s 2.0          | 7.44                          | 7.15             | 1100         | 6.55   | 6.55         | 2.34             | 4.21                  | 4.95             | 4.21           | 4.95              | 5.55           | 6.55             | 5.55           | 6.55                       | 9.29           | 11.94            | 9.29         | 11.94            | 11.25 | 12.31 | 11.25 | 12.31 |
| 356   | 6000s 1.8        | 6.25                          | 6.01             | 1200         | 7.91   | 7.61         | 2.69             | 4.92                  | 6.02             | 4.73           | 5.79              | 5.80           | 7.32             | 5.58           | 7.03                       | 11.03          | 12.43            | 10.60        | 11.95            | 11.03 | 12.43 | 10.60 | 11.95 |
|   | 60s 2.0          | 8.93                          | 8.59             | 1610         | 6.85   | 6.85         | 2.86             | 4.67                  | 5.28             | 4.67           | 5.28              | 5.85           | 6.85             | 5.85           | 6.85                       | 9.29           | 13.41            | 9.29         | 13.41            | 11.42 | 15.03 | 11.42 | 15.03 |
|   | 90s 2.0          | 13.70                         | 13.17            | 2490         | 8.61   | 8.28         | 2.69             | 7.27                  | 8.27             | 6.99           | 7.95              | 8.16           | 8.61             | 7.85           | 8.28                       | 13.52          | 17.01            | 13.00        | 16.36            | 13.52 | 17.01 | 13.00 | 16.36 |
| 406   | 6000s 1.8        | 7.16                          | 6.88             | 1610         | 8.70   | 8.37         | 3.06             | 5.20                  | 6.43             | 5.00           | 6.18              | 6.13           | 8.06             | 5.89           | 7.75                       | 12.40          | 12.97            | 11.92        | 12.47            | 12.40 | 12.97 | 11.92 | 12.47 |
|   | 60s 2.0          | 9.27                          | 8.91             | 1997         | 8.34   | 8.34         | 3.34             | 5.17                  | 6.24             | 5.17           | 6.24              | 6.48           | 8.34             | 6.48           | 8.34                       | 9.38           | 15.10            | 9.38         | 15.10            | 12.62 | 16.42 | 12.62 | 16.42 |
|   | 90s 2.0          | 15.79                         | 15.18            | 3340         | 8.24   | 7.92         | 3.06             | 7.08                  | 8.13             | 6.81           | 7.82              | 8.24           | 8.24             | 7.92           | 7.92                       | 13.08          | 17.59            | 12.58        | 16.91            | 13.08 | 17.59 | 12.58 | 16.91 |

| Long-Term Design Properties of BCI® Joists in Bending ( $K_3 = 1.0$ ) <sup>1, 2</sup> |                  |                               |                  |              |  |              |                  |                       |                  |                |                   |                |                  |                |                            |                |                  |              |                  |       |       |       |       |
|---|------------------|-------------------------------|------------------|--------------|--|--------------|------------------|-----------------------|------------------|----------------|-------------------|----------------|------------------|----------------|----------------------------|----------------|------------------|--------------|------------------|-------|-------|-------|-------|
| Service Class 2 Conditions — (20°C / 85% rh)  |                  |                               |                  |              |  |              |                  |                       |                  |                |                   |                |                  |                |                            |                |                  |              |                  |       |       |       |       |
| Joist Depth   | Joist Type       | Bending Moment Capacity (kNm) |                  |              | Flexural Rigidity (EI) (Nmm <sup>2</sup> x 10 <sup>9</sup> ) |              |                  | Shear Resistance (kN) |                  |                | End Reaction (kN) |                |                  |                | Intermediate Reaction (kN) |                |                  |              |                  |       |       |       |       |
|   |                  | Load Sharing                  | Non-Load Sharing | Load Sharing | Non-Load Sharing   | Load Sharing | Non-Load Sharing | Load Sharing          | Non-Load Sharing | 45mm Bearing   |                   | 89mm Bearing   |                  | 89mm Bearing   |                            | 133mm Bearing  |                  |              |                  |       |       |       |       |
|   |                  |                               |                  |              |  |              |                  |                       |                  | Web Stiffeners |                   | Web Stiffeners |                  | Web Stiffeners |                            | Web Stiffeners |                  |              |                  |       |       |       |       |
|   |                  | No                            | Yes              | No           | Yes  | No           | Yes              | No                    | Yes              | No             | Yes               | No             | Yes              | No             | Yes                        | No             | Yes              | No           | Yes              | No    | Yes   |       |       |
| Load Sharing  | Non-Load Sharing | Load Sharing                  | Non-Load Sharing | Load Sharing | Non-Load Sharing   | Load Sharing | Non-Load Sharing | Load Sharing          | Non-Load Sharing | Load Sharing   | Non-Load Sharing  | Load Sharing   | Non-Load Sharing | Load Sharing   | Non-Load Sharing           | Load Sharing   | Non-Load Sharing | Load Sharing | Non-Load Sharing |       |       |       |       |
| 220   | 4500s 2.0        | 3.18                          | 3.06             | 322          | 3.62   | 3.48         | 1.37             | 2.93                  | 3.52             | 2.82           | 3.38              | 4.09           | 4.68             | 3.93           | 4.50                       | 7.02           | 7.02             | 6.75         | 6.75             | 7.02  | 7.02  | 6.75  | 6.75  |
|   | 60s 2.0          | 5.12                          | 4.92             | 496          | 3.73   | 3.59         | 1.54             | 3.41                  | 4.00             | 3.28           | 3.85              | 4.57           | 5.16             | 4.39           | 4.96                       | 9.14           | 9.21             | 8.79         | 8.86             | 9.14  | 9.21  | 8.79  | 8.86  |
|   | 90s 2.0          | 7.86                          | 7.56             | 759          | 3.73   | 3.59         | 1.60             | 3.41                  | 4.00             | 3.28           | 3.85              | 4.57           | 5.16             | 4.39           | 4.96                       | 9.14           | 9.72             | 8.79         | 9.35             | 9.14  | 9.72  | 8.79  | 9.35  |
| 241   | 4500s 2.0        | 3.52                          | 3.38             | 397          | 3.92   | 3.77         | 1.48             | 2.92                  | 3.52             | 2.82           | 3.38              | 4.09           | 4.68             | 3.93           | 4.50                       | 7.02           | 7.02             | 6.75         | 6.75             | 7.02  | 7.02  | 6.75  | 6.75  |
|   | 6000s 1.8        | 3.70                          | 3.56             | 461          | 5.23   | 5.03         | 1.49             | 3.67                  | 4.04             | 3.53           | 3.88              | 4.20           | 4.45             | 4.04           | 4.28                       | 8.05           | 8.41             | 7.74         | 8.09             | 8.05  | 8.41  | 7.74  | 8.09  |
|   | 60s 2.0          | 5.14                          | 4.94             | 591          | 5.39   | 5.39         | 1.45             | 4.15                  | 4.86             | 4.15           | 4.86              | 5.12           | 5.39             | 5.12           | 5.39                       | 9.19           | 10.17            | 9.19         | 10.17            | 10.80 | 10.95 | 10.80 | 10.95 |
| 302   | 4500s 2.0        | 4.51                          | 4.34             | 664          | 3.92   | 3.77         | 1.82             | 2.93                  | 3.52             | 2.82           | 3.38              | 4.09           | 4.97             | 3.93           | 4.78                       | 7.02           | 7.02             | 6.75         | 6.75             | 7.02  | 7.02  | 6.75  | 6.75  |
|   | 6000s 1.8        | 4.73                          | 4.55             | 770          | 6.13   | 5.89         | 1.87             | 3.82                  | 4.45             | 3.67           | 4.28              | 4.43           | 5.21             | 4.26           | 5.01                       | 8.01           | 8.56             | 7.70         | 8.23             | 8.01  | 8.56  | 7.70  | 8.23  |
|   | 60s 2.0          | 6.68                          | 6.43             | 1010         | 6.55   | 6.55         | 1.94             | 4.21                  | 4.95             | 4.21           | 4.95              | 5.55           | 6.55             | 5.55           | 6.55                       | 9.29           | 11.94            | 9.29         | 11.94            | 11.25 | 12.31 | 11.25 | 12.31 |
| 356   | 6000s 1.8        | 5.63                          | 5.41             | 1110         | 6.87   | 6.61         | 2.20             | 3.94                  | 4.82             | 3.79           | 4.63              | 4.64           | 5.86             | 4.46           | 5.63                       | 8.82           | 9.94             | 8.48         | 9.56             | 8.82  | 9.94  | 8.48  | 9.56  |
|   | 60s 2.0          | 8.04                          | 7.73             | 1480         | 6.85   | 6.85         | 2.37             | 4.67                  | 5.28             | 4.67           | 5.28              | 5.85           | 6.85             | 5.85           | 6.85                       | 9.29           | 13.41            | 9.29         | 13.41            | 11.42 | 15.03 | 11.42 | 15.03 |
|   | 90s 2.0          | 12.32                         | 11.85            | 2300         | 6.88   | 6.62         | 2.20             | 5.81                  | 6.61             | 5.59           | 6.36              | 6.53           | 6.88             | 6.28           | 6.62                       | 10.82          | 13.61            | 10.40        | 13.09            | 10.82 | 13.61 | 10.40 | 13.09 |
| 406   | 6000s 1.8        | 6.44                          | 6.19             | 1490         | 7.57   | 7.28         | 2.51             | 4.16                  | 5.15             | 4.00           | 4.95              | 4.90           | 6.45             | 4.71           | 6.20                       | 9.92           | 10.37            | 9.54         | 9.97             | 9.92  | 10.37 | 9.54  | 9.97  |
|   | 60s 2.0          | 9.27                          | 8.91             | 2000         | 8.34   | 8.34         | 2.77             | 5.17                  | 6.24             | 5.17           | 6.24              | 6.48           | 8.34             | 6.48           | 8.34                       | 9.38           | 15.10            | 9.38         | 15.10            | 12.62 | 16.42 | 12.62 | 16.42 |
|   | 90s 2.0          | 14.21                         | 13.66            | 3090         | 6.58   | 6.33         | 2.51             | 5.67                  | 6.20             | 5.45           | 6.25              | 6.58           | 6.58             | 6.33           | 6.33                       | 10.46          | 14.07            | 10.06        | 13.53            | 10.46 | 14.07 | 10.06 | 13.53 |

| Joist Depth | Joist Weight (kg/m) |           |         |         |
|-------------|---------------------|-----------|---------|---------|
|             | 4500s 2.0           | 6000s 1.8 | 60s 2.0 | 90s 2.0 |
| 220         | 2.97                | -         | 4.08    | 5.69    |
| 241         | 3.12                | 3.69      | 4.23    | 5.83    |
| 302         | 3.55                | 4.12      | 4.66    | 6.26    |
| 356         | -                   | 4.50      | 5.04    | 6.64    |
| 406         | -                   | 4.85      | 5.39    | 7.00    |

**Notes**

- <sup>1</sup> The properties given above are applicable to long-term load duration. Permissible strength values for other load durations may be obtained by multiplying by 1.25 for medium-term loading or 1.5 for short-term loading as detailed in BS5268-2:2002.
- <sup>2</sup> The properties given above presuppose adequate lateral restraint is provided to the compression flange via continuous boarding or discrete restraints applied at maximum centres of 400mm.

<sup>3</sup> For web stiffener specifications and fixing details, see page 18.

<sup>4</sup> The maximum deflection of a uniformly loaded joist can be calculated from the following equation :

$$d = (5wL^4/384EI) + (wL^2/8GA) \text{ where :}$$

w is the uniform load (kN/m)

L is the span (m)

EI is the flexural rigidity obtained from the table

GA is the shear rigidity obtained from the table

## BCI® Joists Used as Rim Joists / Bearers

**Maximum Long-Term Load on BCI® Joists Subject to Uniform Compression Perpendicular to the Joist Direction (Service Classes 1 and 2)**

| Joist Depth | Maximum Load per Metre Run (kN/m) |
|-------------|-----------------------------------|
| 220         | 43.8                              |
| 241         | 42.3                              |
| 302         | 38.0                              |
| 356         | 34.2                              |
| 406         | 32.0                              |

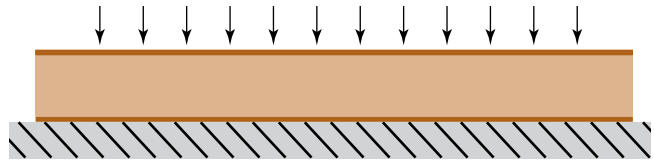

## BCI® Joists Used as Columns / Studs

The maximum axial compression capacity of BCI® Joists used as struts should be based upon the capacity of the flange cross-section only:

$$P_c = \sigma_{c,adm} \times A_f \times k_{12} \times k_3$$

Where:  $P_c$  = maximum axial compression load (N)

$\sigma_{c,adm}$  = 19.5 N/mm<sup>2</sup> for Service Class 1  
 = 17.5 N/mm<sup>2</sup> for Service Class 2

$A_f$  = Total cross-sectional area of the flanges (mm<sup>2</sup>)

$k_{12}$  = Slenderness modification factor from BS5268-2:2002

$k_3$  = Load duration modification factor from BS5268-2:2002

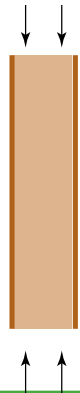

## BCI® Joists Used as Ties

The maximum axial tensile capacity of BCI® Joists used as struts, where both flanges are equally loaded, should be based upon the capacity of the flange cross-section only:

$$P_t = \sigma_{t,adm} \times A_f \times k_3 \times \left( \frac{2440}{L} \right)^{0.125}$$

Where:  $P_t$  = maximum axial tension load (N)

$\sigma_{t,adm}$  = 15.0 N/mm<sup>2</sup> for Service Class 1  
 = 13.5 N/mm<sup>2</sup> for Service Class 2

$A_f$  = Total cross-sectional area of the flanges (mm<sup>2</sup>)

$k_3$  = Load duration modification factor from BS5268-2:2002

$L$  = Member length (mm) [min. value = 2440 mm]



## Allowable Nail Spacings

Nailed joints in VERSA-LAM® flanges of BCI® Joists should be designed using the permissible nail values given in BS 5268-2: 2002 for C27 timber. Nails should be spaced in accordance with the following table:

| Nailing in Wide Face (Perpendicular to Glue Lines) |                   |                    |                                     |   |
|--|-------------------|--------------------|-------------------------------------|---|
| Nail Diameter (mm)                                 | End Distance (mm) | Edge Distance (mm) | Along Face - Parallel to Grain (mm) | Across Face - Perpendicular to Grain (mm) |
| 3.0  | 48                | 15                 | 48                                  | 24  |
| 3.35   | 54                | 17                 | 54                                  | 27  |
| 3.75   | 60                | 19                 | 60                                  | 30  |

| Nailing in Narrow Face (Parallel to Glue Lines) |                   |                    |                                     |   |
|---|-------------------|--------------------|-------------------------------------|---|
| Nail Diameter (mm)                              | End Distance (mm) | Edge Distance (mm) | Along Face - Parallel to Grain (mm) | Across Face - Perpendicular to Grain (mm) |
| 3.0   | 60                | 15                 | 60                                  | 15  |
| 3.35  | 67                | 17                 | 67                                  | 17  |
| 3.75  | 75                | 19                 | 75                                  | 19  |

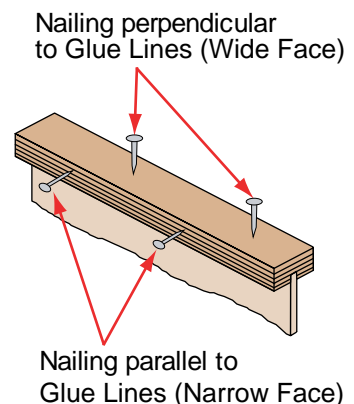





## About Floor Performance

Increasing the stiffness of a floor system will improve its performance and “feel”. The most efficient way of increasing the stiffness of the floor is to deepen the joists — this is simple engineering fact - a 25% increase in joist depth will have the same effect as doubling the joist width or halving the joist centres. A clear justification for the “deeper is cheaper” statement that echoes around the engineered wood product industry. Our designers can easily design the floor to performance levels above the minimum code requirements if so desired.

The performance of a floor is matter of opinion. The “feel” that satisfies one individual may not satisfy another. Many factors affect the perceived performance of a floor. These include:

✓ **The depth of the joist**

The stiffness of a floor can be markedly improved by increasing joist depth. For example, a 25% increase in joist depth will double the floor stiffness.

✓ **The spacing of the joist system**

The stiffness of a floor increases in proportion to reductions in joist spacing.

✓ **Continuous or simple spans**

Allowing joists to span over internal load-bearing walls instead of breaking them at these points can increase floor stiffness by up to 240%.

✓ **The decking / flooring material**

Thicker decking slightly improves floor performance — 22mm chipboard increases floor stiffness by 2%\* compared to 18mm chipboard and means less 'local' deflection under foot.

✓ **The fixing of the decking material to the joist**

Gluing the floor deck to the joists significantly improves floor stiffness, by as much as 70%.\*

✓ **The ceiling material below the joist**

Directly applied ceiling boards can improve floor performance by up to 3%.\*

✓ **Level bearings**

Unlevel bearings can mean joists feel "spongy" under foot near bearing positions.

✓ **The location of walls and furniture**

The position and size of dead loads on floors can either dampen or exaggerate the dynamic response of floors under foot.

*\*Figures established from independent laboratory research carried out on behalf of the UK Government.*

## Floor Design Criteria

BCI® Joists are designed for floor applications using the principles of BS5268–2:2002 and the joist properties contained in BBA Certificate 99/3620. In general, it can be assumed that floors in modern centrally heated buildings will achieve a Service Class 1 moisture condition. Uniformly distributed dead and imposed loads will be assumed across the whole floor unless otherwise directed. Imposed loads are to be taken from BS6399:Part1:1996. Examples are shown below. Dead loads can be taken from the schedule of material weights tabulated below. All loads should be confirmed by the Building Designer.

| Schedule of Material Dead Weights |                   |  |                         |
|-----------------------------------|-------------------|--|-------------------------|
| Floor Decking                     | kN/m <sup>2</sup> | Ceiling Finishes                       | kN/m <sup>2</sup>       |
| 18mm Chipboard                    | 0.13              | 5mm Plaster Skim                       | 0.05                    |
| 22mm Chipboard                    | 0.16              | 15mm Plasterboard                      | 0.11                    |
| 18mm T&G Boarding                 | 0.10              | 12.5mm Plasterboard                    | 0.09                    |
| 22mm T&G Boarding                 | 0.12              | 12.5mm Firecheck P/board               | 0.11                    |
| 15mm OSB                          | 0.11              | <b>Partition Loads</b>                 | <b>kN/m<sup>2</sup></b> |
| 18mm OSB                          | 0.13              | 12.5mm Plasterboard on timber studwork | 0.29                    |
| 15mm Plywood                      | 0.10              | <b>Insulation</b>                      | <b>kN/m<sup>2</sup></b> |
| 19mm Plywood                      | 0.12              | Rock Wool (25mm)                       | 0.01                    |
| 18mm Particleboard <sup>/1</sup>  | 0.22              | Glass Fibre (50mm)                     | 0.01                    |
| 22mm Particleboard <sup>/1</sup>  | 0.27              |  |                         |
| 16mm S.W. Boarding                | 0.08              |  |                         |
| 19mm S.W. Boarding                | 0.09              |  |                         |
| 12.5mm Sound Resistant P/board    | 0.11              |  |                         |
| 19mm Gypsum Plank                 | 0.14              |  |                         |

<sup>/1</sup>Particleboard refers to cement bonded particleboard Type T1 Flooring.

| Standard Imposed Load Allowances |   |
|----------------------------------|---|
| Intended Room Usage              | kN/m <sup>2</sup>   |
| Domestic Floors                  | 1.5   |
| Office Floors                    | 2.5   |
| Computer Rooms                   | 3.5   |
| Storage Rooms                    | 2.4/m height of storage   |
| Gymnasium                        | 5.0   |
| Stationery Stores                | 4.0/m height of storage   |
| Balconies                        | Same as rooms to which they give access (min 1.5 for domestic use, 4.0 for public / office use) |
| Billiard Rooms                   | 2.0   |
| Areas with Fixed Seating         | 4.0   |
| Concert Halls                    | 5.0   |
| Bedrooms in Hotels/Motels        | 2.0   |
| Dining Rooms/Lounges Cafes       | 2.0   |

<sup>/1</sup>Taken from BS6399:Part1:1996

BS6399:Part 1 recommends that the loads for all permanent partitions are applied in the given locations as dead loads. In practice, a standard dead load of 0.75kN/m<sup>2</sup> is generally assumed which makes allowance for a standard floor construction (22mm chipboard decking + 15mm plasterboard ceiling), supporting internal non load-bearing partitions above. Exceptionally, this may be reduced to 0.5kN/m<sup>2</sup> where no partition walls are known to exist, or increased to a higher value where a heavier form of construction is used.

The minimum stiffness permitted for floors in BS5268-2:2002 is defined by the deflection being limited to 0.3% of the span or 14mm, whichever is the lesser. Boise Cascade recommends that BCI® Joists are designed to higher stiffness criteria in order to provide superior floor performance. NHBC technical standards require that the maximum deflection is limited to 12mm. Floor performance can be enhanced consistently in practice if the decking is glued to the joist platform, as highlighted by the factors affecting floor performance. This step is also recommended as a basis for ensuring superior floor performance in practice.

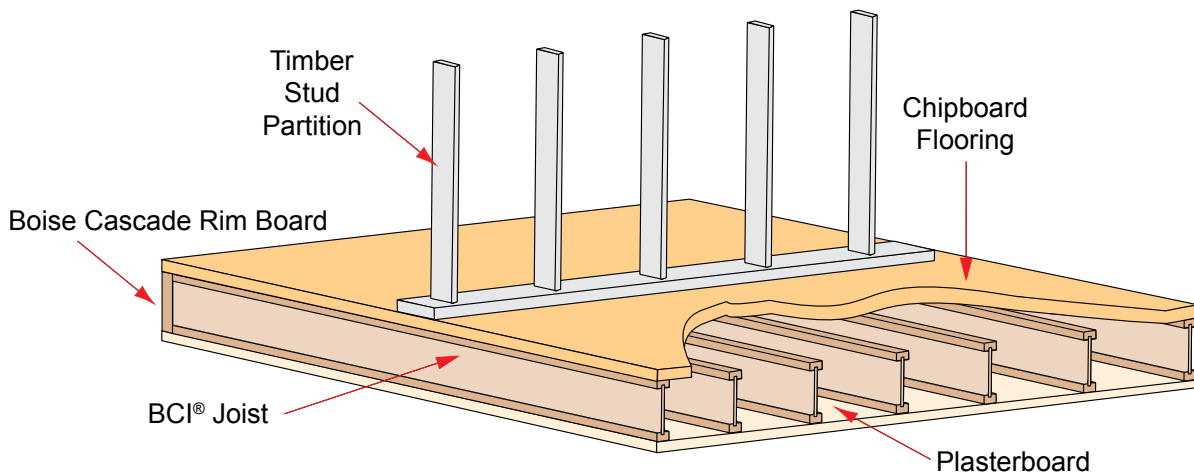

## Residential Floor Span Tables

The table below represents maximum spans for a range of floor performance levels for joists in a single span application. Multispanning a joist over intermediate supports can result in improved





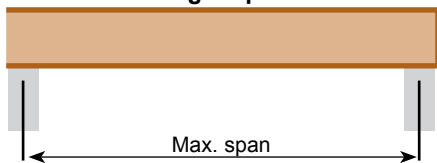



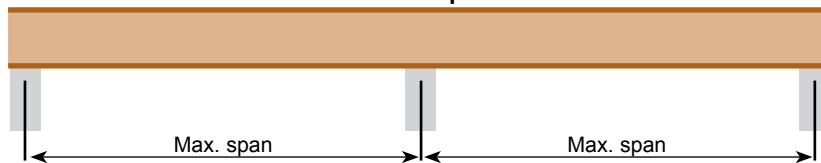

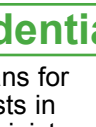











performance or the ability to span further. Please refer to BC CALC® or Boise Cascade Engineered Wood Products Engineering for further details.

Single Span

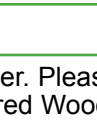

Double Span



| Joist Depth (mm)  | BCI® Joist Type | Single Span<br>     | Maximum spans (m) for domestic construction <sup>/1, /2</sup>         |        |        |        |
|---|-----------------|--|---|--------|--------|--------|
|   |                 |  | BS5268-2:2002 NHBC Recommended<br>(12mm max instantaneous deflection) |        |        |        |
|   |                 |  | 600c/c  | 480c/c | 400c/c | 300c/c |
|  220mm   | 4500s 2.0       | Single Span<br>     | 3.731   | 4.033  | 4.232  | 4.563  |
|   | 60s 2.0         | Single Span<br>     | 4.220   | 4.479  | 4.700  | 5.071  |
|   | 90s 2.0         | Single Span<br>     | 4.661   | 4.950  | 5.199  | 5.612  |
|  241mm   | 4500s 2.0       | Single Span<br>    | 4.001   | 4.246  | 4.455  | 4.805  |
|   | 6000s 1.8       | Single Span<br>   | 4.143   | 4.398  | 4.616  | 4.979  |
|   | 60s 2.0         | Single Span<br>   | 4.391   | 4.664  | 4.897  | 5.287  |
|   | 90s 2.0         | Single Span<br>   | 4.871   | 5.178  | 5.441  | 5.879  |
|  302mm  | 4500s 2.0       | Single Span<br>   | 4.543   | 4.821  | 5.060  | 5.458  |
|   | 6000s 1.8       | Single Span<br>  | 4.705   | 4.994  | 5.242  | 5.656  |
|   | 60s 2.0         | Single Span<br> | 5.023   | 5.335  | 5.601  | 6.046  |
|   | 90s 2.0         | Single Span<br> | 5.545   | 5.896  | 6.196  | 6.697  |
|  356mm | 6000s 1.8       | Single Span<br> | 5.153   | 5.470  | 5.742  | 6.196  |
|   | 60s 2.0         | Single Span<br> | 5.528   | 5.870  | 6.163  | 6.652  |
|   | 90s 2.0         | Single Span<br> | 6.084   | 6.470  | 6.800  | 7.350  |
|  406mm | 6000s 1.8       | Single Span<br> | 5.542   | 5.884  | 6.177  | 6.665  |
|   | 60s 2.0         | Single Span<br> | 5.964   | 6.333  | 6.649  | 7.177  |
|   | 90s 2.0         | Single Span<br> | 6.541   | 6.957  | 7.312  | 7.905  |

**Notes :**

<sup>/1</sup> All spans quoted are “engineered spans” measured between centres of bearing points. Minimum bearing lengths required are 45mm at joist ends and 89mm at intermediate supports.

<sup>/2</sup> All spans quoted are for standard domestic loading (including allowance for internal partitions) – 0.75kN/m<sup>2</sup> dead loading; 1.5kN/m<sup>2</sup> imposed loading.



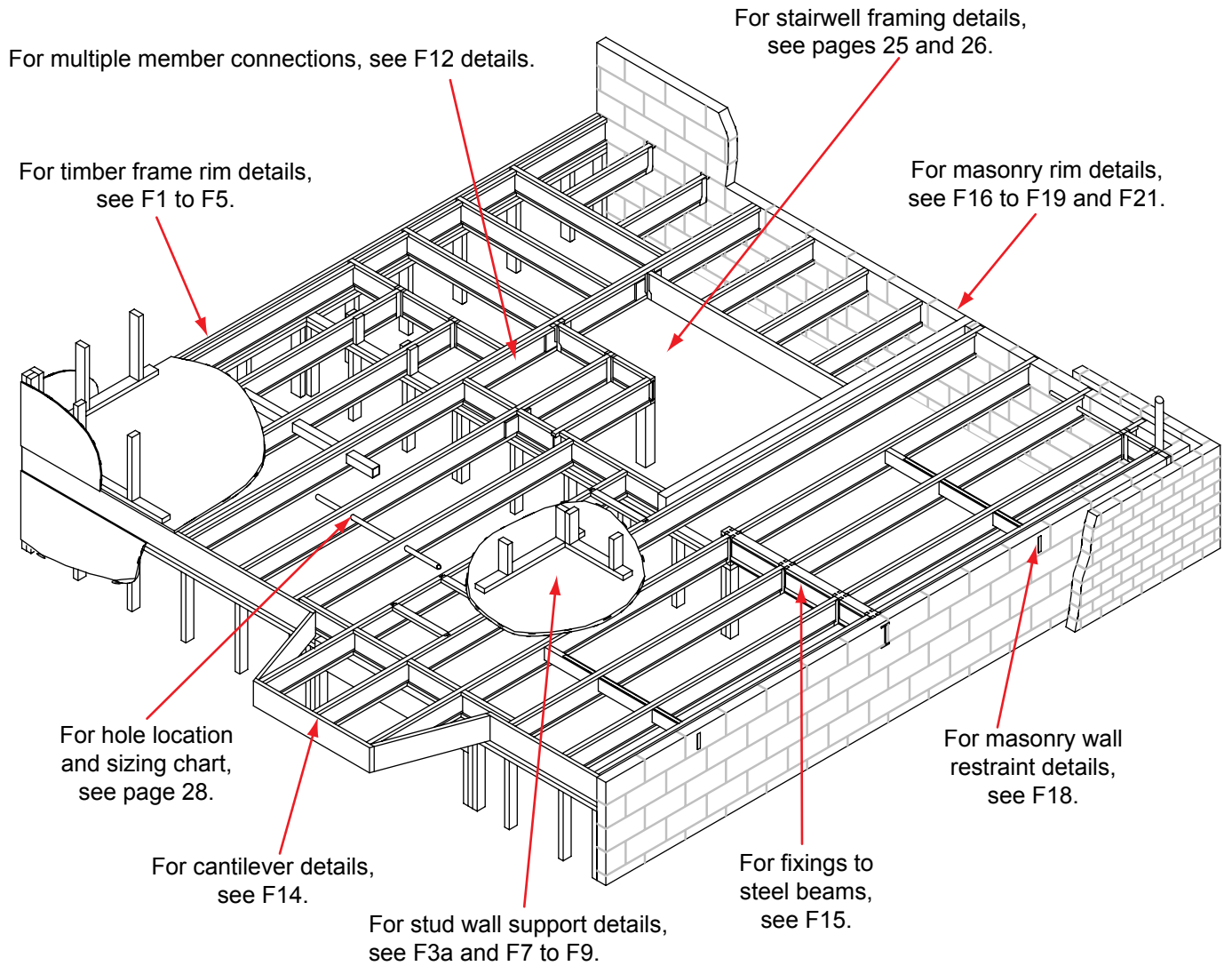

Solid blocking or herring-bone strutting is NOT required on the SIMPLE FRAMING SYSTEM®. For installation stability, see Temporary Construction Bracing details on page 27. The following pages display typical floor details. Others are available by request.



## F1 Fixing at end bearing.

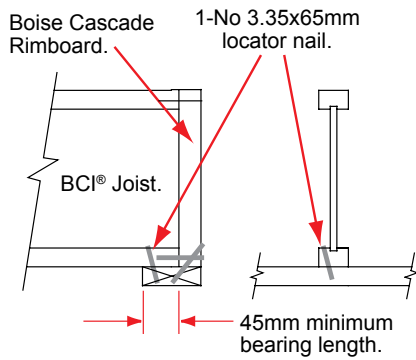

Note: To avoid splitting flange, start locator nail at least 38mm from end. Nails will need to be driven at an angle to prevent splitting of bearing plate.

## F1a Party wall end bearing.

For alternative detail, see F4a

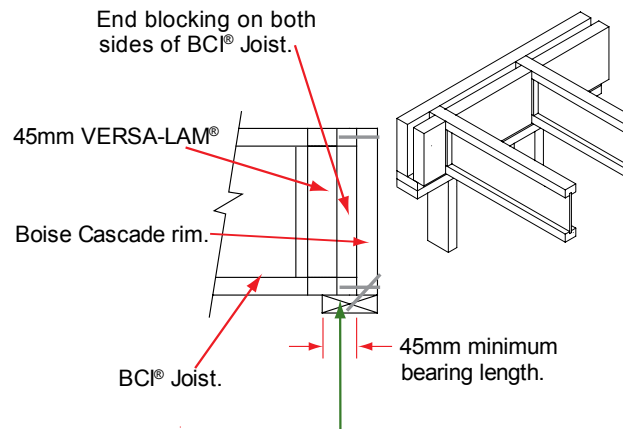

Note: To avoid splitting flange, start locator nail at least 38mm from end. Nails will need to be driven at an angle to prevent splitting of bearing plate.

## F2 BCI® Rim blocking.

Note: Nail BCI® rim blocking to wallplate using 3.35x65mm nails each side at 300mm centres. Skew nail top of blocking to joist.

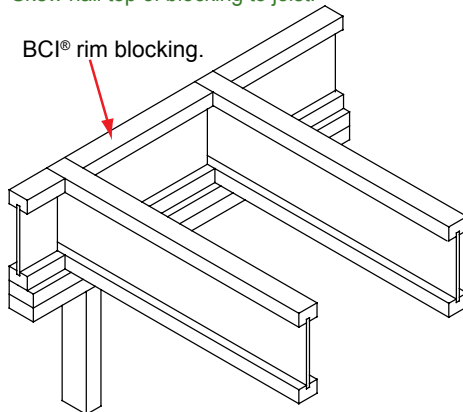

## F3a Non load-bearing stud wall (perpendicular to joist).

Perpendicular non load-bearing stud wall.

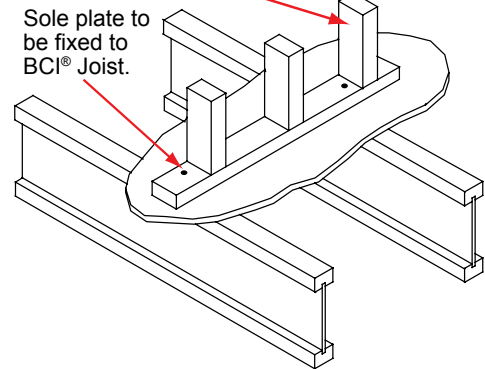

## F4 VERSA-LAM® or VERSA-STRAND® Rim (perpendicular to joist - external wall).

Note: Nail Boise Cascade rim board to BCI® Joists with 2 - 3.35x65mm nails, one at the top and one at the bottom (see detail F1).

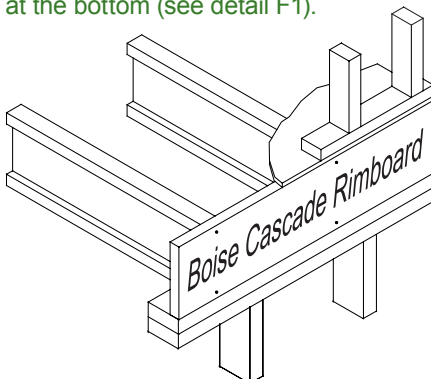

Note: Skew nail Boise Cascade rimboard to wallplate using 3.35x65mm nails at 300mm centres.

## F4a VERSA-LAM® or VERSA-STRAND® Rim (perpendicular to joist - party wall).

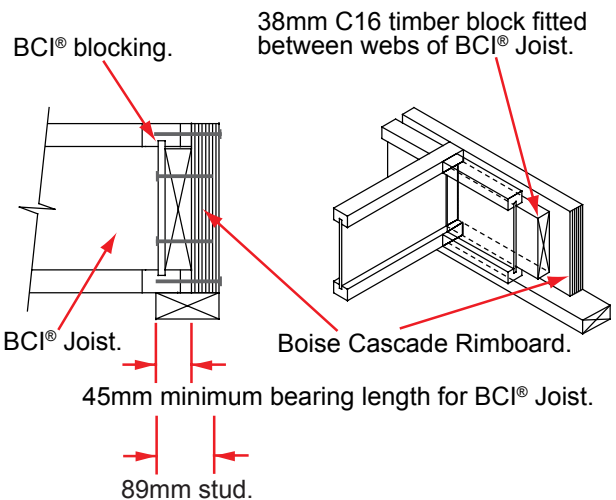

## F4d

## VERSA-BLOC™.

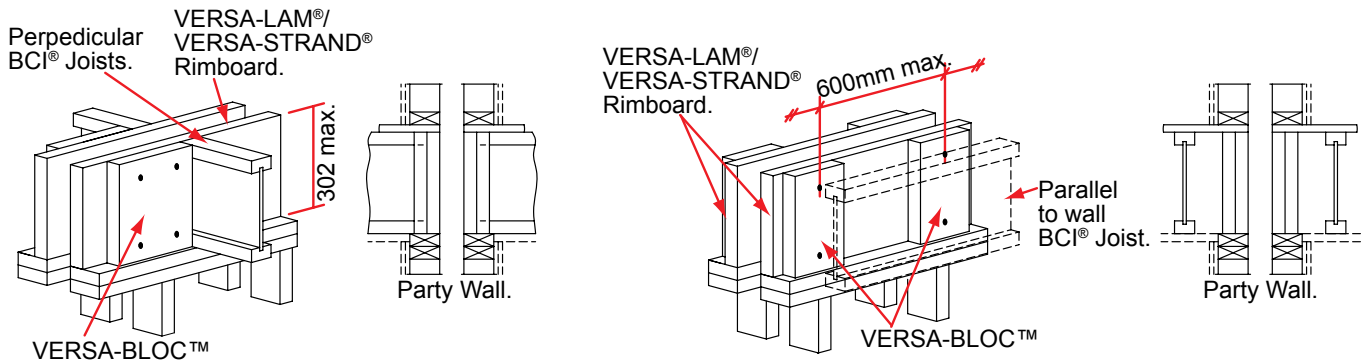

For Conditions of Use and Fixing Specifications for VERSA-BLOC™, please refer to Boise Cascade EWP Technical Bulletin No 1-10.

## F5 VERSA-LAM® or VERSA-STRAND® Rim (parallel to joist - external wall).

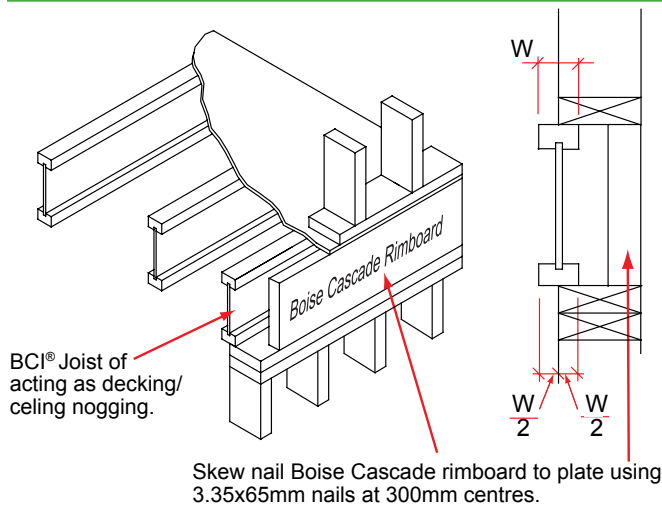

## F5a VERSA-LAM® or VERSA-STRAND® Rim (parallel to joist - party wall).

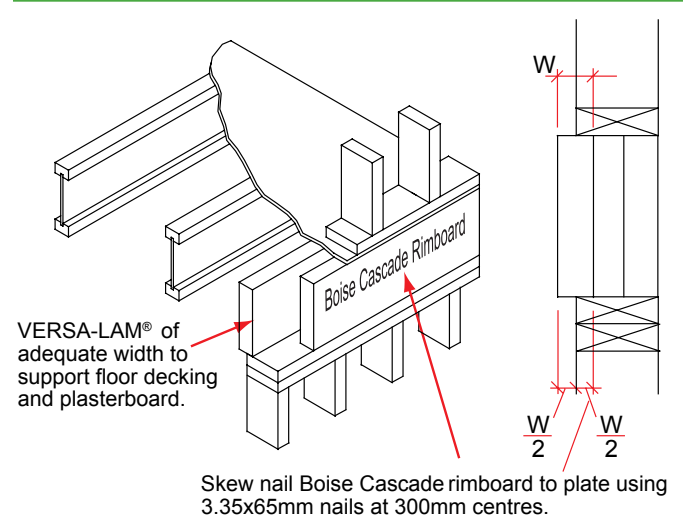

## F6 Joist spliced on load-bearing wall.

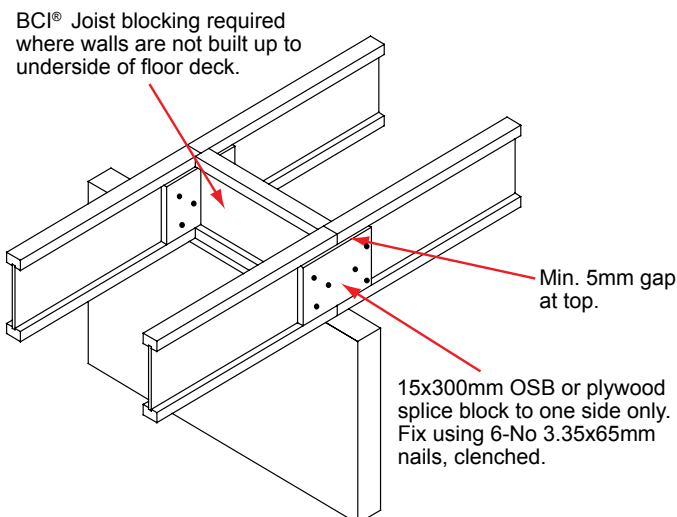

## F7 Non load-bearing stud wall (parallel to joist).

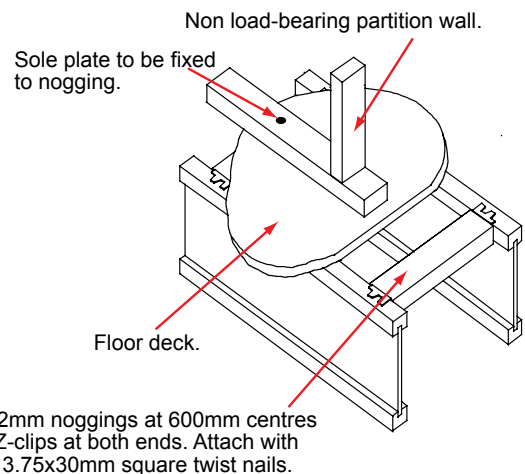



## F8 Wall to wall load transfer (BCI® Joist blocking).

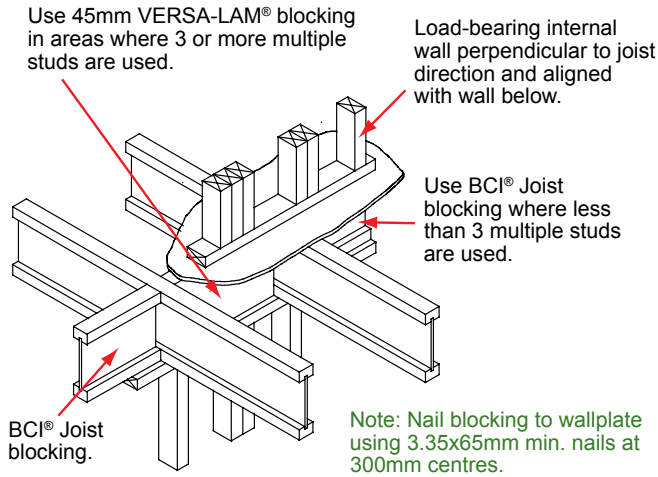

## F8a Wall to wall load transfer (squash blocks).

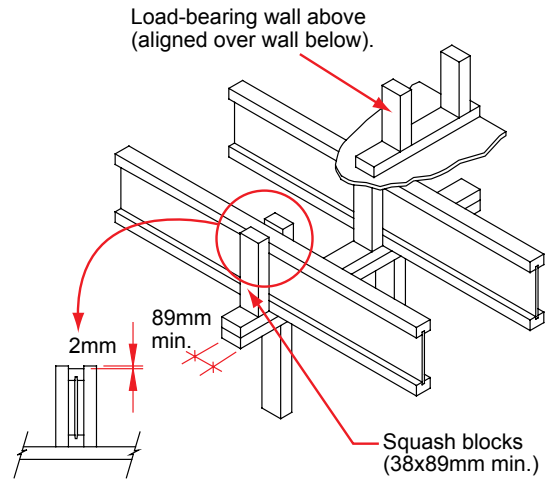

## F9 Concentrated load transfer (squash blocks).

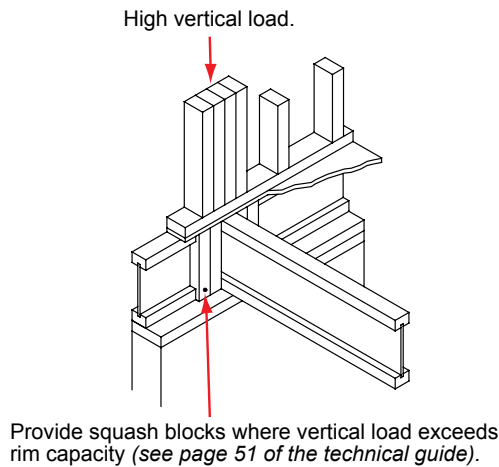

## F11 Backer block (face mount hanger).

Note: Fix backer block using 8-No 3.35x65mm nails clenched (see F11b). Use 100mm nails for 90s series joist.

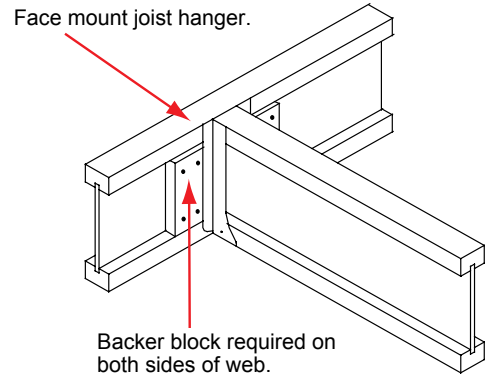

## F10

## Web stiffeners (fixing and specification).

Web stiffeners may be used to increase allowable reaction values in the applications below.

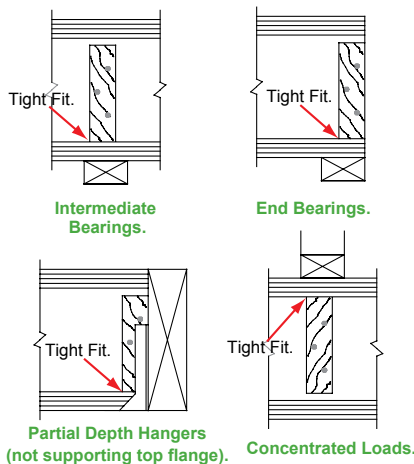

Small gap: 3mm min. 50mm max.

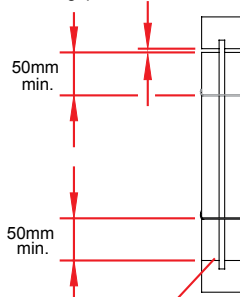

| Joist Depth | Fixings        |
|-------------|----------------|
| 220         | 2-No 3.35x65mm |
| 241         | 2-No 3.35x65mm |
| 302         | 3-No 3.35x65mm |
| 356         | 5-No 3.35x65mm |
| 406         | 6-No 3.35x65mm |

Note: Use 3.35 x 90mm nails for 90s Series Joists.

All Nails to be 3.35 x 65mm driven through and clenched over on far side.

| OSB or Plywood web stiffener: |              |
|-------------------------------|--------------|
| 4500s Series                  | 16x60mm min. |
| 6000s Series                  | 22x60mm min. |
| 60s Series                    | 22x60mm min. |
| 90s Series                    | 38x60mm min. |

Note: Web stiffeners are not required for BCI® Joists unless used in hangers that do not extend up to restrain the top flange of the BCI® Joist or as required by design.

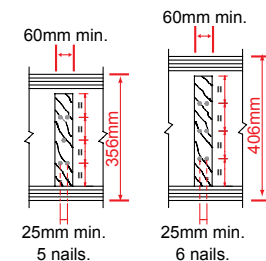
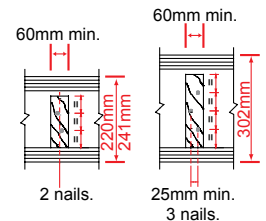

## F11a Backer block (top hung hanger).

Note: Fix backer block using 8-No 3.35x65mm nails clenched (see F11b). Use 100mm nails for 90s series joist.

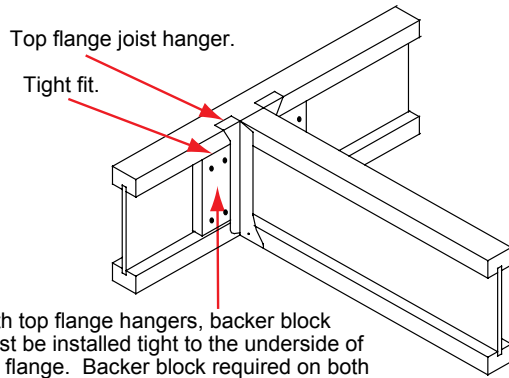

With top flange hangers, backer block must be installed tight to the underside of top flange. Backer block required on both sides of web.

## F11b Backer block (fixing and specification).

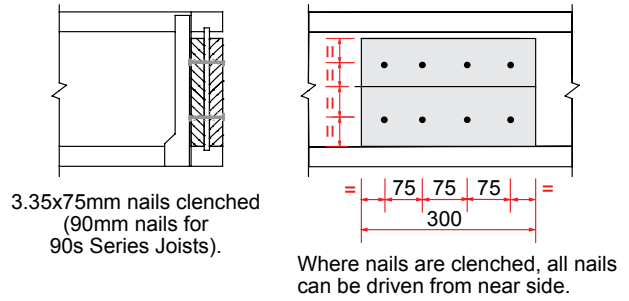

3.35x75mm nails clenched (90mm nails for 90s Series Joists).

Where nails are clenched, all nails can be driven from near side.

| Series | Backer Block Thickness  | Depth | Backer Block Depths |
|--------|-------------------------|-------|---------------------|
| 4500s  | 18mm wood panel         | 220mm | 122mm               |
| 6000s  | 25mm wood panel         | 241mm | 147mm               |
| 60s    | 25mm wood panels        | 302mm | 219mm               |
| 90s    | 18mm + 22mm wood panels | 356mm | 269mm               |
|        |                         | 406mm | 319mm               |

## F11c No backer block required (Cullen U hanger).

U Hanger fixed using 3.75x30mm square twist nails through all holes

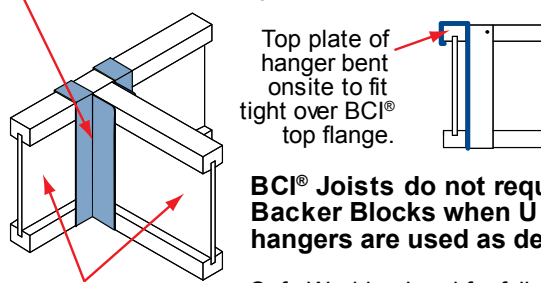

Top plate of hanger bent onsite to fit tight over BCI® top flange.

**BCI® Joists do not require Backer Blocks when U hangers are used as detailed.**

BCI® Joists (60s & 90s range only).

Safe Working Load for fully nailed hanger as detailed above is **4.63kN** (long term).

Hangers to be used fully in accordance with **Cullen Building Products** specifications.

## F11d No backer block required (Simpson Strong-Tie ITB hanger).

ITB Hanger fixed using a minimum of 12-No 3.75x30mm square twist nails into flanges of supporting joist.

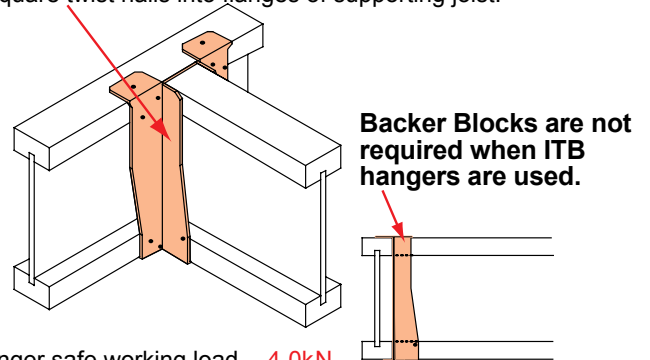

**Backer Blocks are not required when ITB hangers are used.**

Hanger safe working load - **4.0kN**.

Hangers to be used in accordance with **Simpson Strong-Tie®** specifications.

## F12 Filler block (fixing and specification).

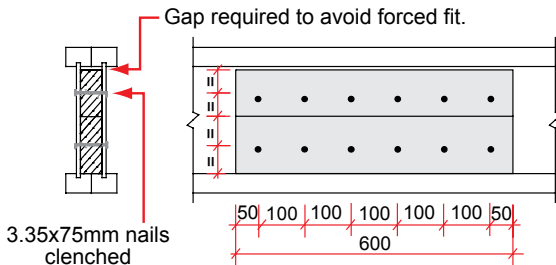

3.35x75mm nails clenched

| Series | Filler Block Thickness | Depth | Filler Block Depth |
|--------|------------------------|-------|--------------------|
| 4500s  | 35mm Timber            | 220mm | 122mm              |
| 6000s  | 47mm Timber            | 241mm | 147mm              |
| 60s    | 47mm Timber            | 302mm | 97mm + 122mm       |
| 90s    | 75mm Timber            | 356mm | 122mm + 147mm      |
|        |                        | 406mm | 147mm + 172mm      |

## F12a 2-ply BCI® filler block.

Fix 2-ply BCI® Joists together using filler blocks at all bearing points, at incoming load positions, and at max 3.6m centres (see F12b).

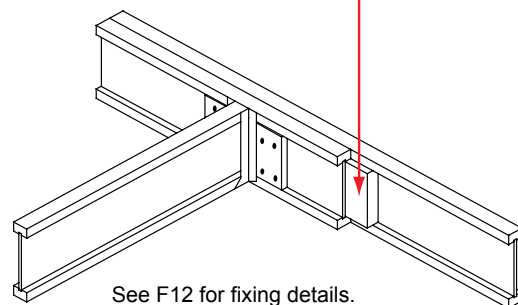

See F12 for fixing details.

## F12b Filler block (short length option).

Note: Maximum spacing between filler blocks to be 3.6 metres. Intermediate filler blocks should be installed between bearing and incoming load positions.

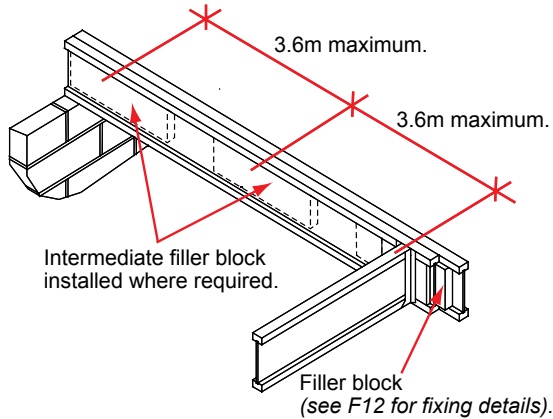

## F12c Filler block (full length option).

Note: A continuous filler and backer block should be considered where numerous incoming joists occur. (See F11b and F12 for fixing details.)

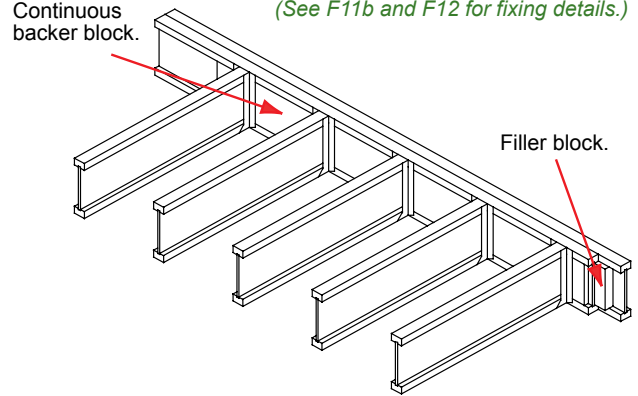

## F12d 2-ply BCI® (Cullen I-clip).

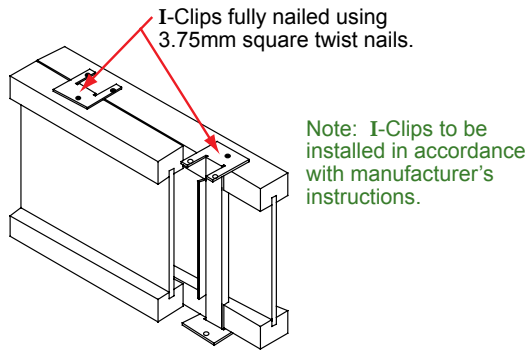

Fix 2-ply BCI® Joists together using I-Clips located within 200mm of all bearing points and incoming load positions and at max 2.0m centres (see F12e).

## F12e Cullen I-Clip (Localized connection).

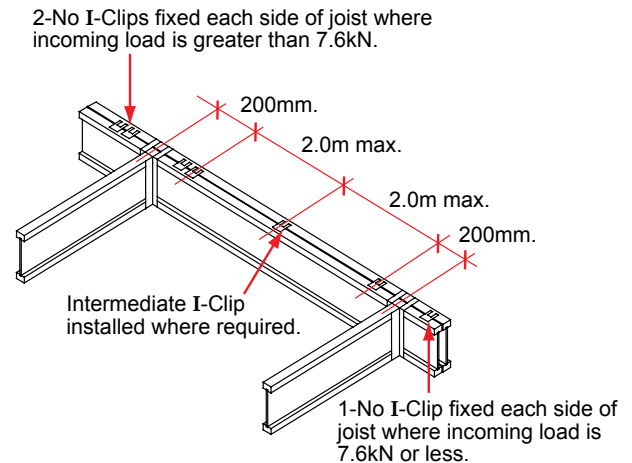

## F12f Cullen I-Clip (Multiple connection).

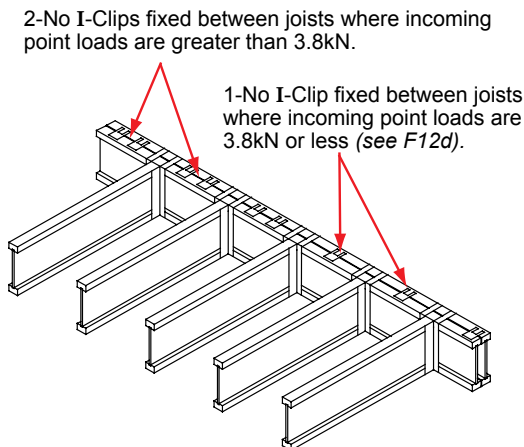

## F13 BCI® Joist to VERSA-LAM® connection.

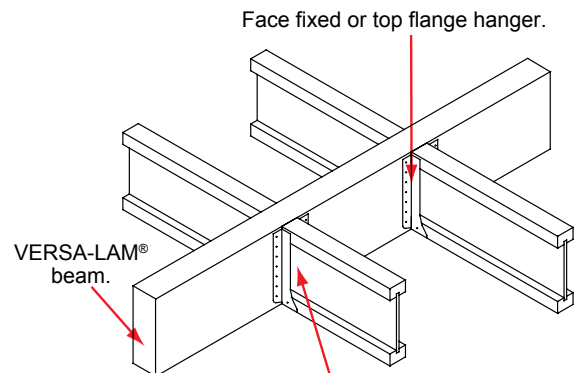

Note: Web stiffeners are required where sides of hanger do not extend up to give restraint to the top flange (see F10).



## F14 Typical standard cantilever.

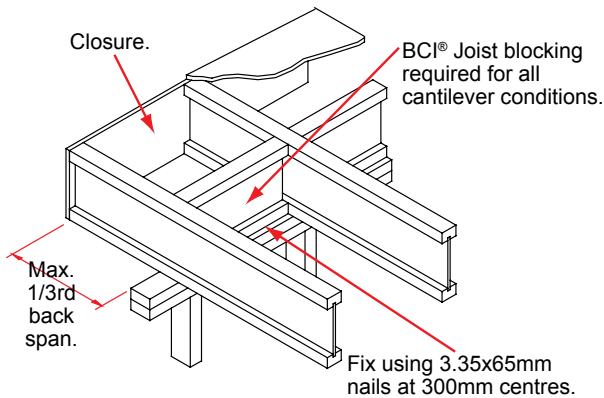

## F14a Typical cantilever with wall support.

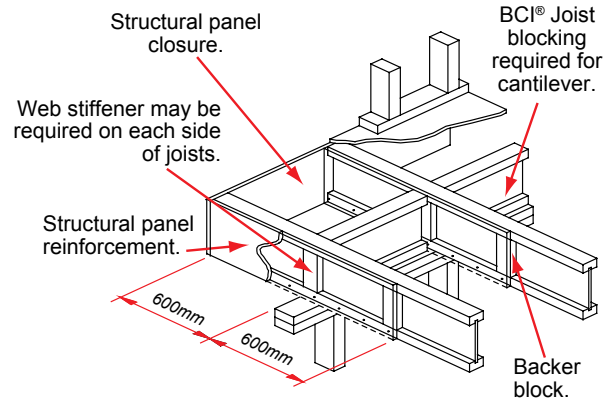

## F15 Support at steel beam (top flange hanger on timber plate).

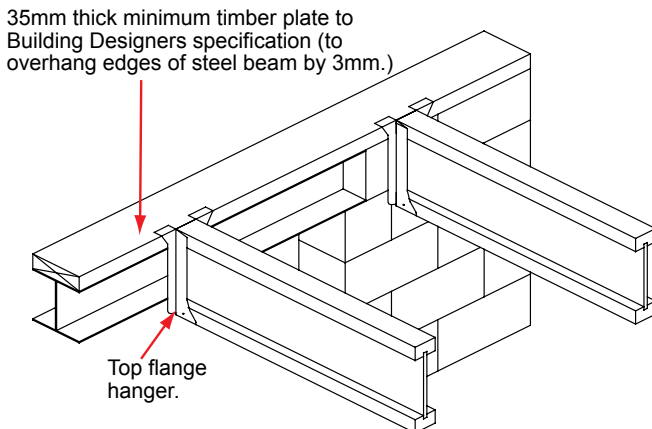

## F15a Steel beam support within floor (face fixed hanger with timber packing).

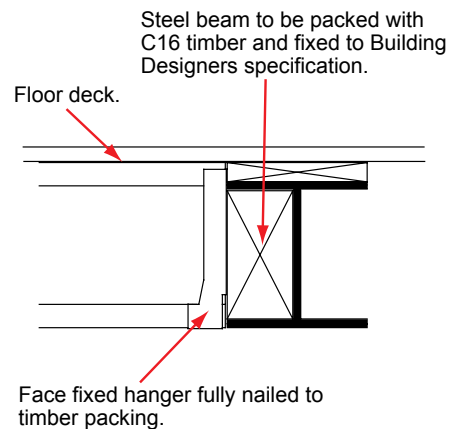

## F15b Steel beam support at edge of floor (face fixed hanger with timber packing).

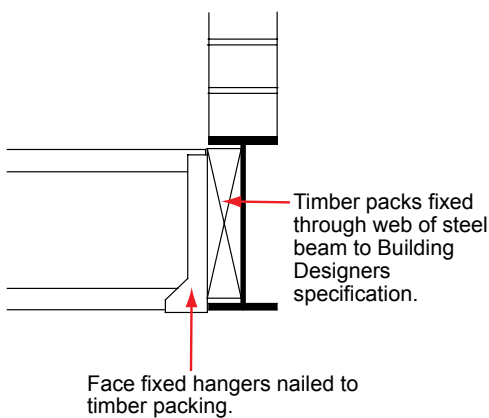

## F15c Steel beam support (masonry hanger shot fired to steel).

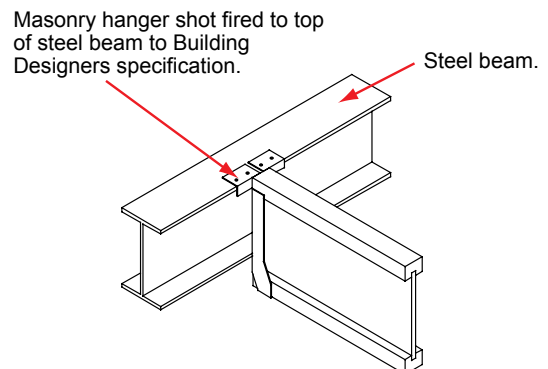

## F15d VERSA-LAM® notched into steel beam.

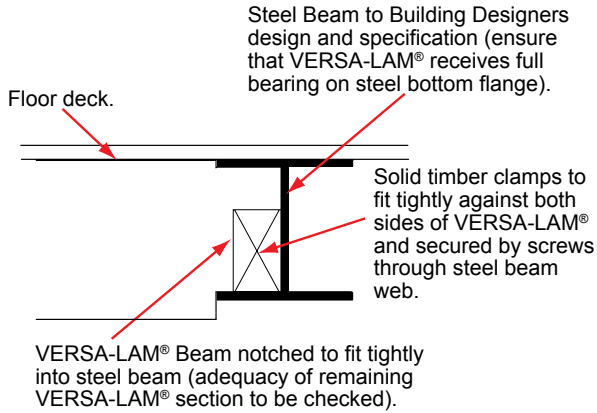

## F16 Perimeter nogging (timber).

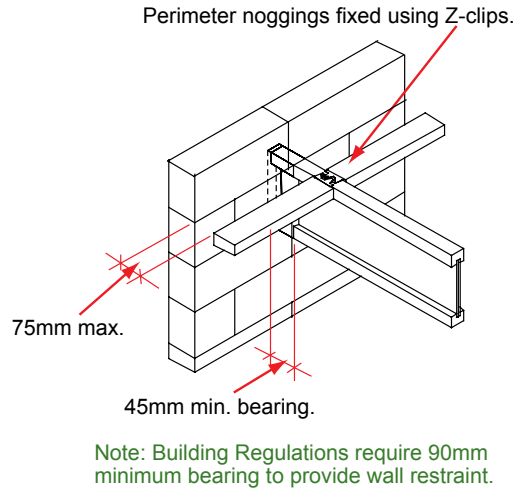

## F17 Proprietary End Seal.

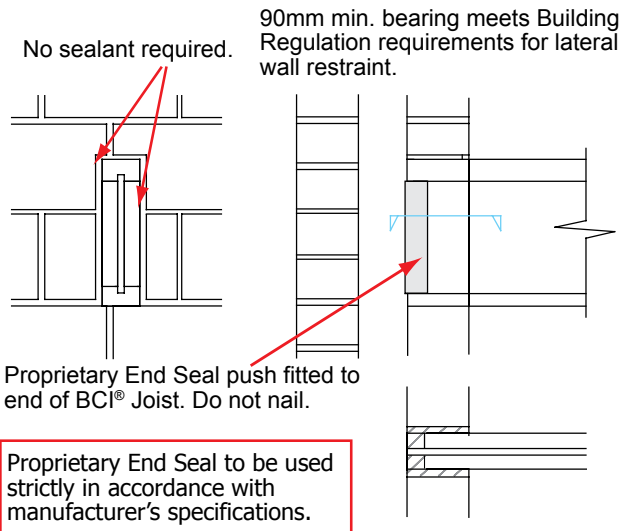

## F17a Plywood packer and silicone sealant.

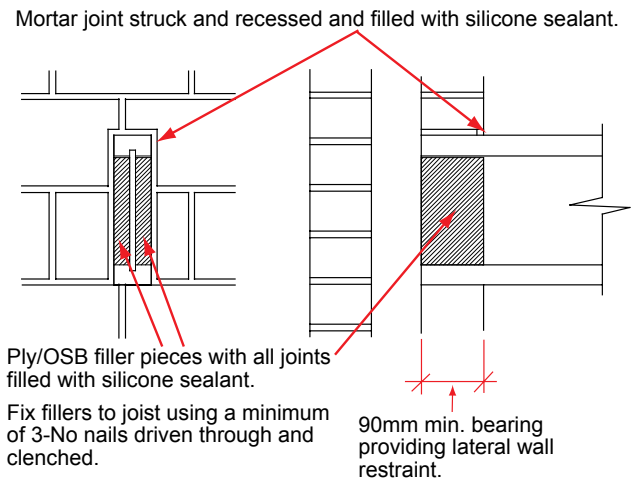

## F17e Ledger beam fixed to masonry.

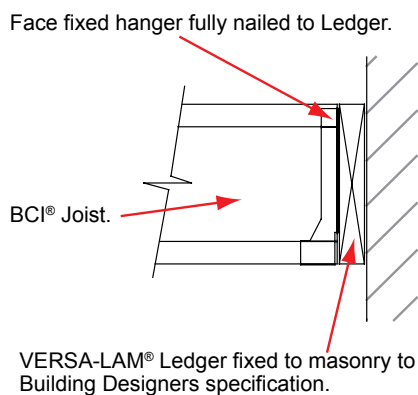

## F18 Lateral restraint for masonry (strap through BCI® Joist).

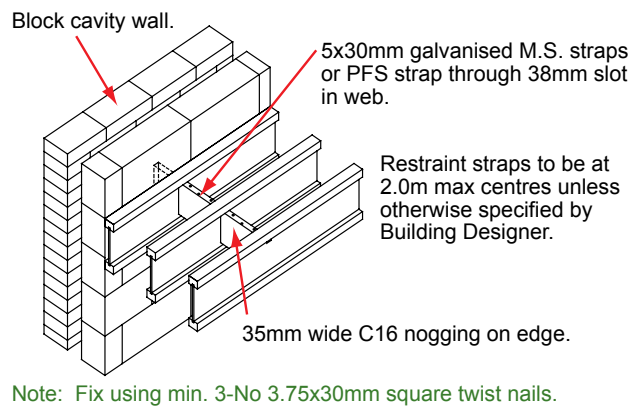

## F18a Lateral restraint for masonry (strap through 241mm BCI® Joist).

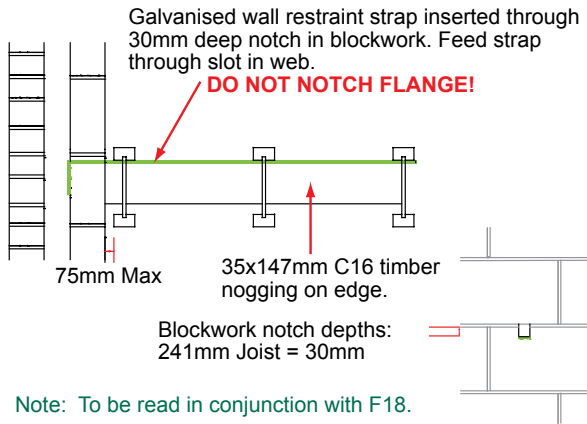

Note: To be read in conjunction with F18.

## F18b Lateral restraint for masonry (strap through 302mm or deeper BCI® Joist).

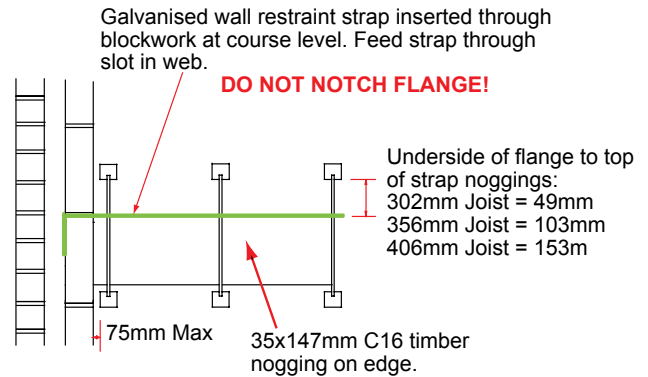

Note: To be read in conjunction with F18.

## F18c Lateral restraint for masonry (perpendicular strap over BCI® Joist).

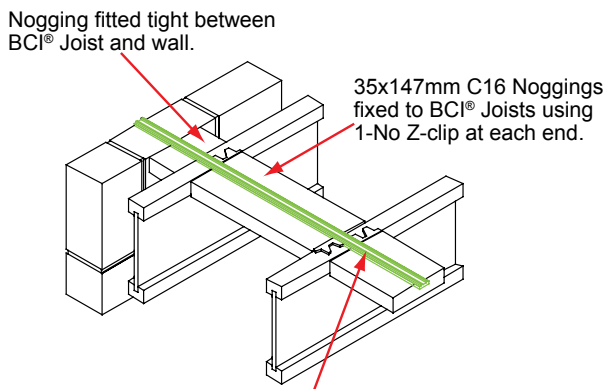

Note: PFS Restraint Strap fixed using min. 8-No 3.75x30mm long square twist nails.

## F18d Lateral restraint for masonry (strap to side of hanger supported BCI® Joist).

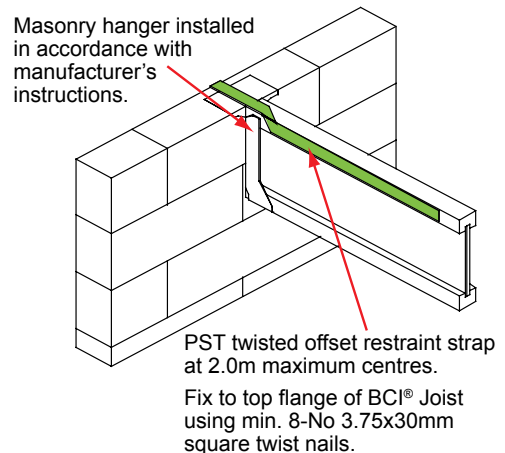

## F18e Lateral restraint for masonry (Simpson Strong-Tie Safety Fast Hanger).

Safety Fast Masonry hanger fitted with Mini-strap to provide lateral wall restraint installed in accordance with manufacturer's instructions.

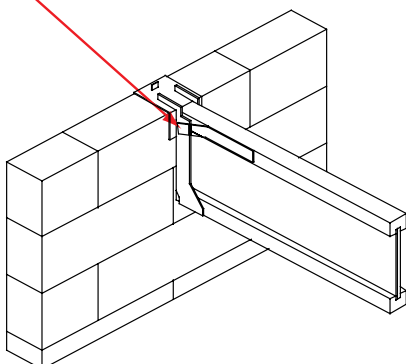

## F19 Continuous BCI® Joist through masonry wall.

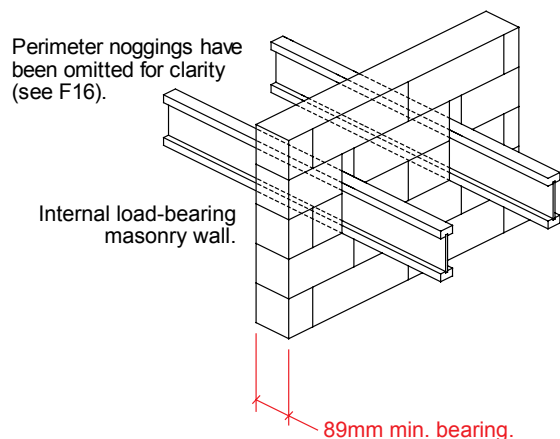



## F20 Stair to Multi-ply BCI® Joist header.

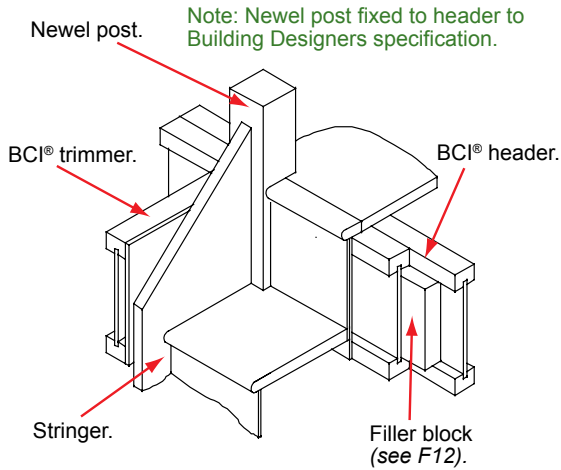

## F20a Stair to VERSA-LAM® header.

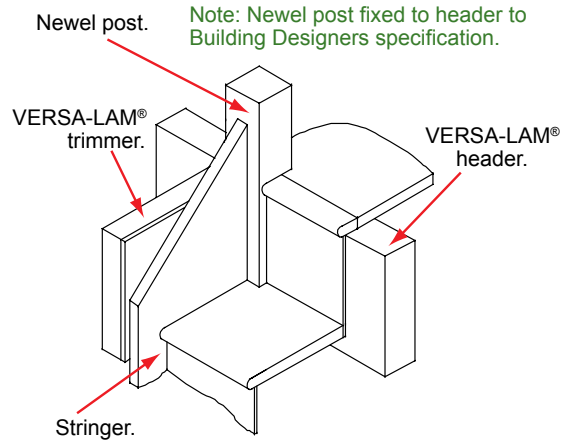

## F20b Stair to BCI® Joist header.

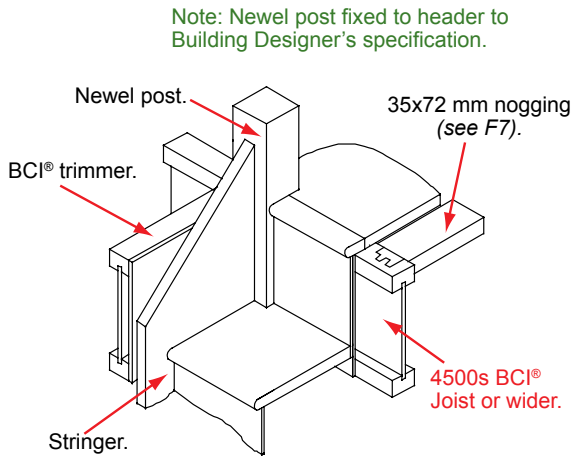

## F21 Masonry support for VERSA-LAM® beams.

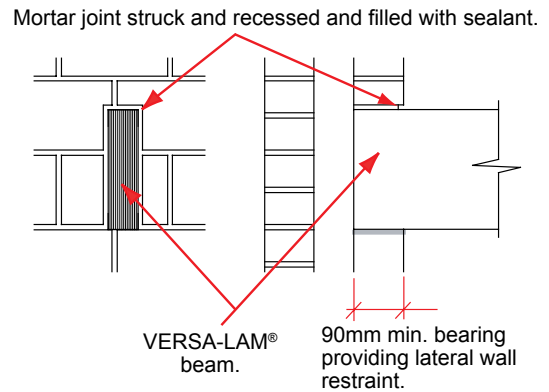

## F22 Hoist to BCI® Joist fixing.

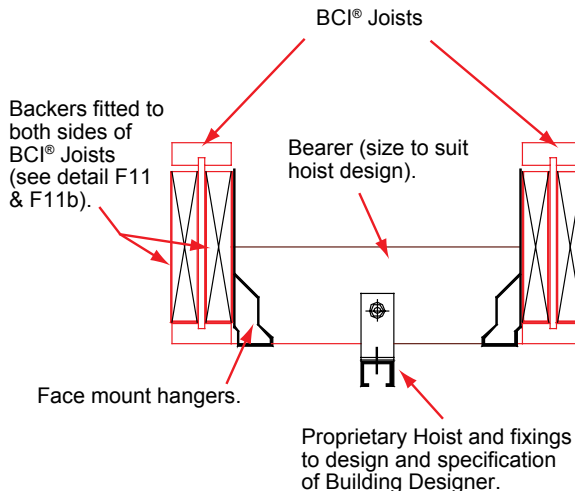

## F23 Temporary platform at stairwell.

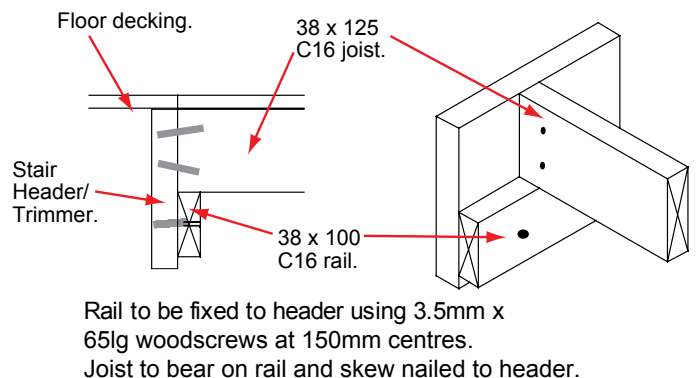

## Framing Around Stair Openings

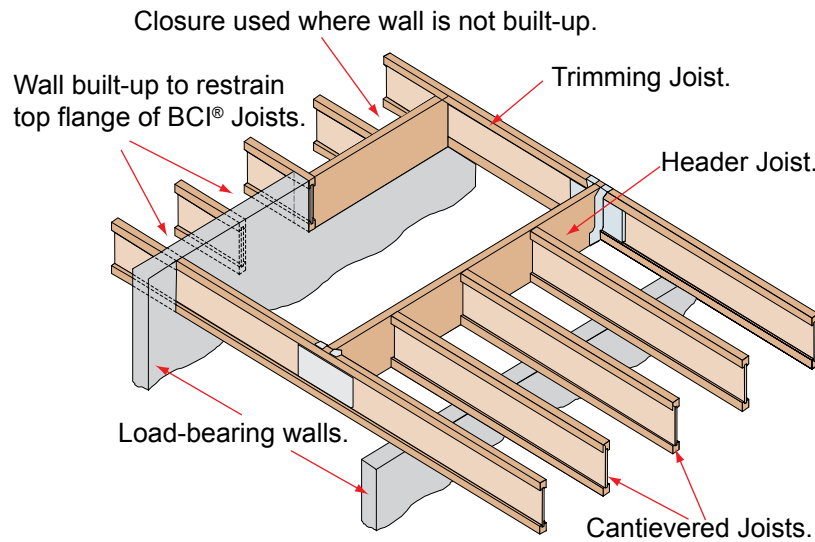

When framing around stair openings in floors, it is often possible to cantilever the oncoming BCI® joists over an adjacent load-bearing wall, provided an adequate fixing exists between the header joist and the trimming joist either side.

Full scale laboratory tests on floors framed in this manner have highlighted the important role the decking plays in this arrangement in acting as a structural diaphragm, and of the importance of the header joist/trimming joist connection, particularly when the decking is discontinuous in the vicinity of the openings (i.e. decking joints occur).

Based on these laboratory tests, suitable framing/fixing arrangements for this situation are recommended below.

Two alternative framing/fixing details are recommended when framing around stairwells, depending upon the ratio of the cantilever length to the back span of the joists in question, as follows:

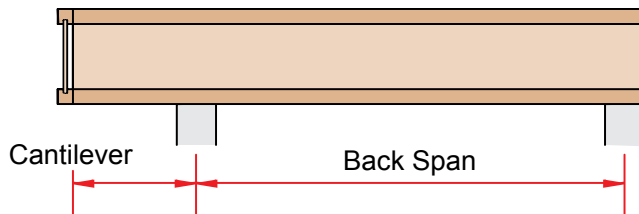

**If in doubt, please ask!**

Boise Cascade  
Engineering on  
01420 590078

| Back span to cantilever ratio | Recommended Detail (See details overleaf)                      |
|-------------------------------|--|
| Up to 3 : 1                   | No cantilever possible – Split joists over wall –Use Detail B  |
| 3 – 5 : 1                     | Use Detail A   |
| Over 5 : 1                    | No cantilever possible – Split joists over wall – Use Detail B |

Based upon the above guidance, the following look-up tables provide a quick reference to the appropriate framing detail for a range of back span/cantilever ratios:

| STAIRWELL FRAMING DETAIL REFERENCE TABLE (See details overleaf) |                |      |      |      |      |      |      |      |      |
|---|----------------|------|------|------|------|------|------|------|------|
| Cantilever distance (mm)  | Back span (mm) |      |      |      |      |      |      |      |      |
|   | 2000           | 2500 | 3000 | 3500 | 4000 | 4500 | 5000 | 5500 | 6000 |
| 600   | A              | A    | A    | B    | B    | B    | B    | B    | B    |
| 700   | B              | A    | A    | A    | B    | B    | B    | B    | B    |
| 800   | B              | A    | A    | A    | A    | B    | B    | B    | B    |
| 900   | B              | B    | A    | A    | A    | A    | B    | B    | B    |
| 1000  | B              | B    | A    | A    | A    | A    | A    | B    | B    |
| 1100  | B              | B    | B    | A    | A    | A    | A    | A    | B    |
| 1200  | B              | B    | B    | B    | A    | A    | A    | A    | A    |
| 1300  | B              | B    | B    | B    | A    | A    | A    | A    | A    |
| 1400  | B              | B    | B    | B    | B    | A    | A    | A    | A    |
| 1500  | B              | B    | B    | B    | B    | A    | A    | A    | A    |

Where cantilever arrangements are required around stairwells in non-domestic applications, contact Boise Cascade Engineered Wood Products Engineering to establish which of the above details will apply or for a specific framing detail engineered to suit the situation.

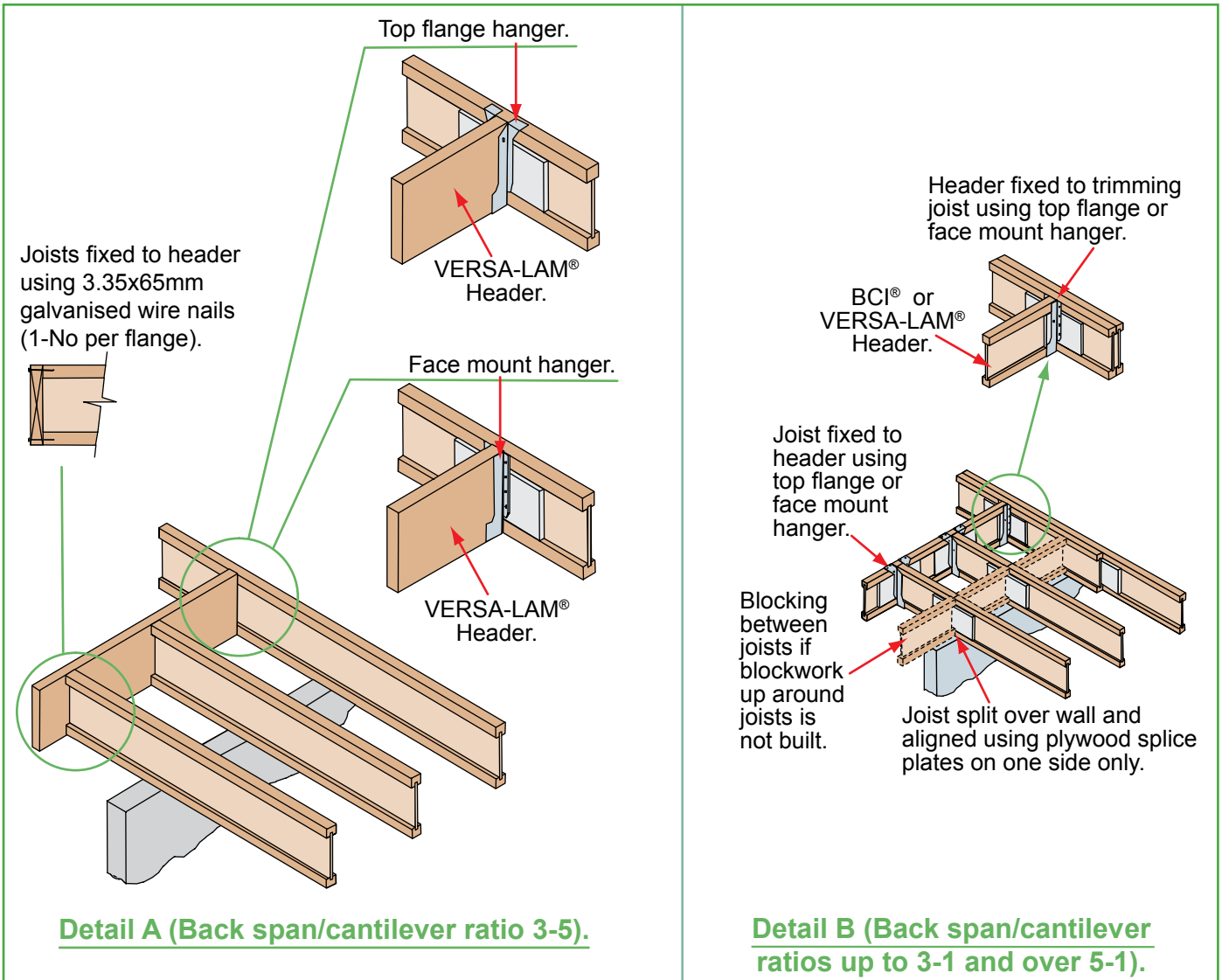

## Load Bearing External Cantilever Details

BCI® Joists which support loads at the ends of cantilevers may require reinforcement, depending upon the magnitude of the cantilever and the loading imposed. Three reinforcement conditions exist:

1. **No reinforcement required – see non load-bearing cantilever detail F14.**
2. **18mm x 1220mm structural panel reinforcement nailed one side of joist.**
3. **18mm x 1220mm structural panel reinforcement nailed both sides of joist.**

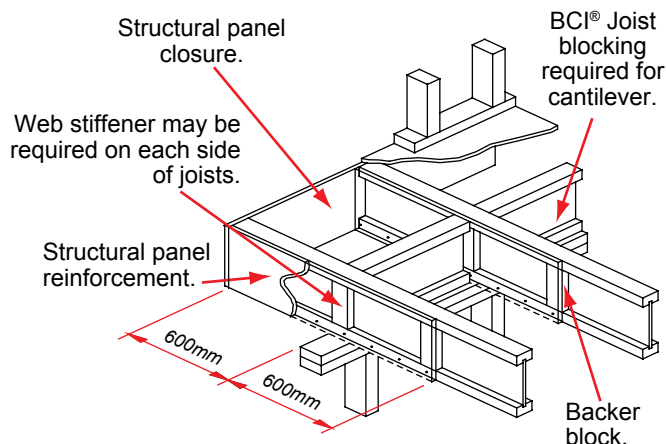

Panel reinforcement should be 18mm WBP plywood or OSB to match the full depth of the BCI® Joist. Nail to the BCI® Joist with 3.35x65mm nails at 150mm centres and nail with 4-No 3.35x65mm nails into backer block. When reinforcing both sides, stagger nails to avoid splitting.

To establish which reinforcement detail applies to any particular cantilever arrangement, contact Boise Cascade Engineered Wood Products Engineering 01420 590078.

**A lateral restraint system must be established at the end of each floor bay to prevent buckling sideways or rollover. This can be done by using temporary braces (shown below) or by fixing sheathing over the first 1.2m of joists and installing timber blocking beneath. All joists in the floor bay must then be connected back to this braced section by way of continuous longitudinal binders prior to allowing workers or placing construction loads on the floor. In long bays, install additional braced sections not greater than 12m apart.**

Continuous longitudinal binder installed over timber blocks.

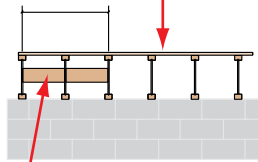

38x125mm min. timber blocks or BCI® blocking over min. 3 joists or 1.2m.

**Note: Serious accidents can result from insufficient attention to proper bracing during construction. Accidents can be avoided under normal conditions by following these guidelines.**



BCI® Joist top flanges must remain straight within a tolerance of 12mm from true horizontal alignment and within a tolerance of 3mm from true vertical alignment.

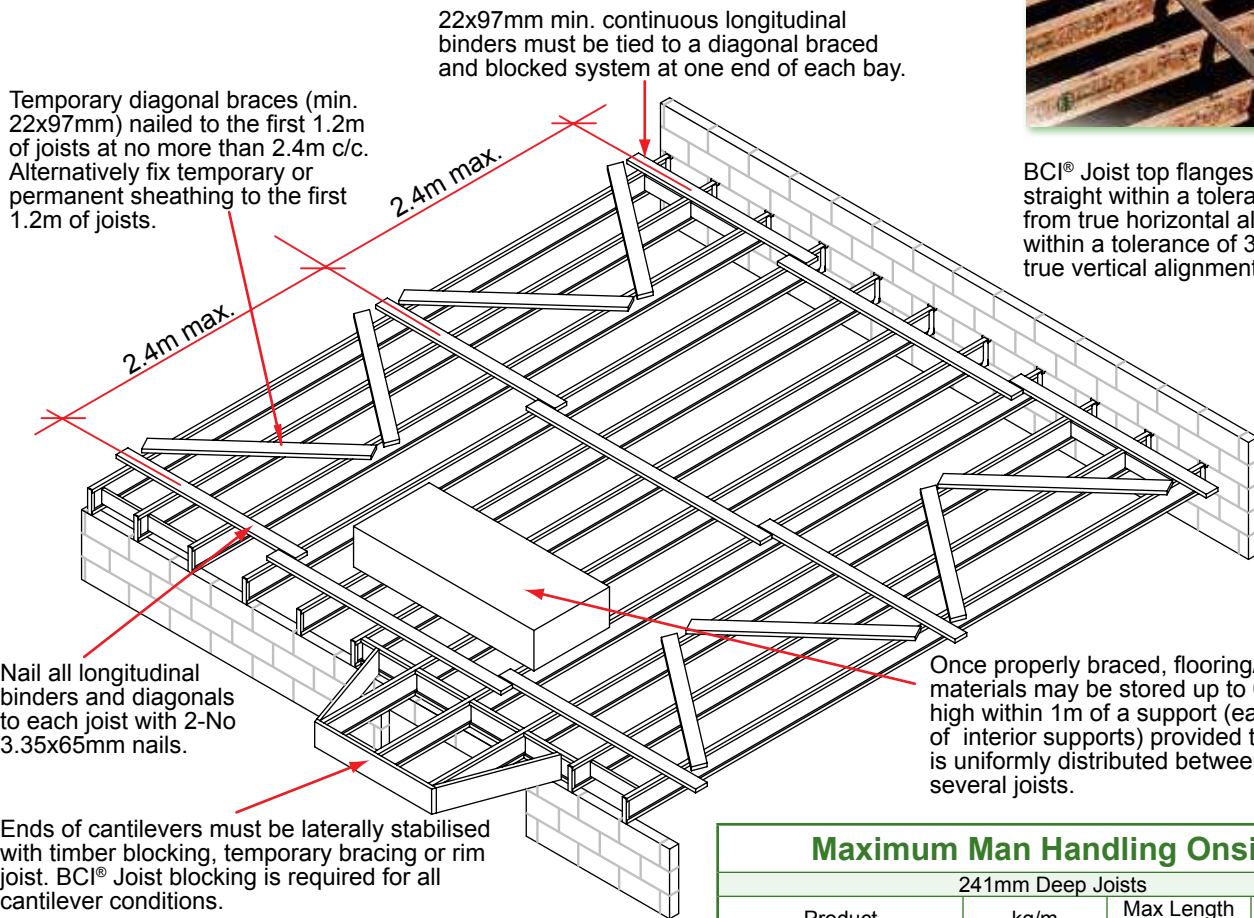

### Safety Warning

**DO NOT ALLOW WORKERS ON BCI® JOISTS UNTIL ALL BLOCKING, HANGERS, RIM JOISTS AND TEMPORARY BRACING ARE COMPLETED AS SPECIFIED ABOVE.**

Without bracing, lateral buckling or rollover is highly probable under light construction loads (e.g., a worker with material in hand).



Don't stack building materials on unbraced joists.

### Maximum Man Handling Onsite.

| 241mm Deep Joists |       |                     |                     |
|-------------------|-------|---------------------|---------------------|
| Product           | kg/m  | Max Length 1 Person | Max Length 2 Person |
| BCI® 4500s        | 3.12  | 8.01                | 16.02               |
| BCI® 6000s        | 3.69  | 6.77                | 13.55               |
| BCI® 60s          | 4.23  | 5.91                | 11.82               |
| BCI® 90s          | 5.83  | 4.29                | 8.58                |
| VERSA-LAM® 38mm   | 6.04  | 4.14                | 8.28                |
| VERSA-LAM® 45mm   | 7.16  | 3.49                | 6.98                |
| VERSA-LAM® 89mm   | 14.16 | 1.77                | 3.54                |
| VERSA-LAM® 133mm  | 21.15 | 1.18                | 2.36                |
| 302mm Deep Joists |       |                     |                     |
| Product           | kg/m  | Max Length 1 Person | Max Length 2 Person |
| BCI® 4500s        | 3.55  | 7.04                | 14.08               |
| BCI® 6000s        | 4.12  | 6.06                | 12.12               |
| BCI® 60s          | 4.66  | 5.36                | 10.72               |
| BCI® 90s          | 6.26  | 3.99                | 7.98                |
| VERSA-LAM® 38mm   | 7.57  | 3.30                | 6.60                |
| VERSA-LAM® 45mm   | 8.97  | 2.79                | 5.58                |
| VERSA-LAM® 89mm   | 17.74 | 1.41                | 2.82                |
| VERSA-LAM® 133mm  | 26.51 | 0.95                | 1.89                |



## Hole Location and Sizing

BCI® Joists are manufactured with 38mm round prestamped knockouts in the web at approx. 305mm centres for ventilation, electrical wiring or small plumbing.

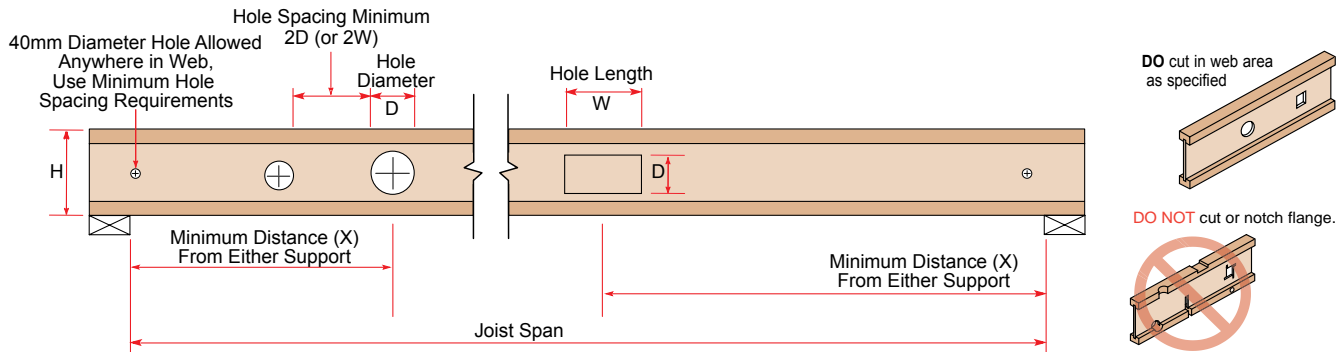

**MINIMUM DISTANCE (X) FROM CENTRELINE OF HOLE TO ANY END SUPPORT (m)**

| BCI® Joist Depth (mm) | Joist Span (m) | CIRCULAR HOLES<br>Hole Diameter [D] (mm) |      |      |      |      |      |      | RECTANGULAR HOLES<br>Hole Height [D] x Length [W] (mm) |           |           |           |           |           |           |           |           |  |  |
|-----------------------|----------------|--|------|------|------|------|------|------|--|-----------|-----------|-----------|-----------|-----------|-----------|-----------|-----------|--|--|
|                       |                | 75                                       | 100  | 125  | 150  | 175  | 200  | 250  | 100 x 100  | 125 x 250 | 150 x 150 | 150 x 300 | 175 x 350 | 200 x 200 | 200 x 400 | 250 x 250 | 250 x 350 |  |  |
| 220                   | 3.0            | 0.16                                     | 0.16 | 0.21 |      |      |      |      | 0.40   | 0.86      |           |           |           |           |           |           |           |  |  |
|                       | 3.5            | 0.16                                     | 0.16 | 0.45 |      |      |      |      | 0.65   | 1.11      |           |           |           |           |           |           |           |  |  |
|                       | 4.0            | 0.16                                     | 0.36 | 0.70 |      |      |      |      | 0.90   | 1.36      |           |           |           |           |           |           |           |  |  |
|                       | 4.5            | 0.28                                     | 0.61 | 0.95 |      |      |      |      | 1.15   | 1.61      |           |           |           |           |           |           |           |  |  |
|                       | 5.0            | 0.53                                     | 0.86 | 1.12 |      |      |      |      | 1.40   | 1.86      |           |           |           |           |           |           |           |  |  |
| 241                   | 3.5            | 0.16                                     | 0.16 | 0.27 | 0.58 |      |      |      | 0.54   | 1.03      | 0.96      | 1.18      |           |           |           |           |           |  |  |
|                       | 4.0            | 0.16                                     | 0.21 | 0.52 | 0.83 |      |      |      | 0.79   | 1.28      | 1.21      | 1.43      |           |           |           |           |           |  |  |
|                       | 4.5            | 0.16                                     | 0.46 | 0.77 | 1.08 |      |      |      | 1.04   | 1.53      | 1.46      | 1.68      |           |           |           |           |           |  |  |
|                       | 5.0            | 0.40                                     | 0.71 | 1.02 | 1.33 |      |      |      | 1.29   | 1.78      | 1.71      | 1.93      |           |           |           |           |           |  |  |
| 302                   | 4.0            | 0.16                                     | 0.16 | 0.21 | 0.26 | 0.43 | 0.73 |      | 0.34   | 0.95      | 0.74      | 1.10      | 1.24      | 1.14      | 1.38      |           |           |  |  |
|                       | 4.5            | 0.16                                     | 0.16 | 0.21 | 0.38 | 0.68 | 0.98 |      | 0.59   | 1.20      | 0.99      | 1.35      | 1.49      | 1.39      | 1.63      |           |           |  |  |
|                       | 5.0            | 0.16                                     | 0.16 | 0.33 | 0.63 | 0.93 | 1.23 |      | 0.84   | 1.45      | 1.24      | 1.60      | 1.74      | 1.64      | 1.88      |           |           |  |  |
|                       | 5.5            | 0.16                                     | 0.28 | 0.58 | 0.88 | 1.18 | 1.48 |      | 1.09   | 1.70      | 1.49      | 1.85      | 1.99      | 1.89      | 2.13      |           |           |  |  |
| 356                   | 4.5            | 0.16                                     | 0.16 | 0.21 | 0.26 | 0.31 | 0.54 | 1.08 | 0.39   | 1.05      | 0.74      | 1.17      | 1.30      | 1.10      | 1.42      | 1.45      | 1.57      |  |  |
|                       | 5.0            | 0.16                                     | 0.16 | 0.21 | 0.26 | 0.53 | 0.79 | 1.33 | 0.64   | 1.30      | 0.99      | 1.42      | 1.55      | 1.35      | 1.67      | 1.70      | 1.82      |  |  |
|                       | 5.5            | 0.16                                     | 0.16 | 0.24 | 0.51 | 0.78 | 1.04 | 1.58 | 0.89   | 1.55      | 1.24      | 1.67      | 1.80      | 1.60      | 1.92      | 1.95      | 2.07      |  |  |
|                       | 6.0            | 0.16                                     | 0.22 | 0.49 | 0.76 | 1.03 | 1.29 | 1.83 | 1.14   | 1.80      | 1.49      | 1.92      | 2.05      | 1.85      | 2.17      | 2.20      | 2.32      |  |  |
| 406                   | 5.0            | 0.16                                     | 0.16 | 0.21 | 0.26 | 0.31 | 0.36 | 0.68 | 0.16   | 0.95      | 0.51      | 1.08      | 1.22      | 0.89      | 1.35      | 1.27      | 1.46      |  |  |
|                       | 5.5            | 0.16                                     | 0.16 | 0.21 | 0.26 | 0.31 | 0.36 | 0.93 | 0.38   | 1.20      | 0.76      | 1.33      | 1.47      | 1.14      | 1.60      | 1.52      | 1.71      |  |  |
|                       | 6.0            | 0.16                                     | 0.16 | 0.21 | 0.26 | 0.32 | 0.61 | 1.18 | 0.63   | 1.45      | 1.01      | 1.58      | 1.72      | 1.39      | 1.85      | 1.77      | 1.96      |  |  |
|                       | 6.5            | 0.16                                     | 0.16 | 0.21 | 0.29 | 0.57 | 0.86 | 1.43 | 0.88   | 1.70      | 1.26      | 1.83      | 1.97      | 1.64      | 2.10      | 2.02      | 2.21      |  |  |

**Notes:**

- Table assumes joists are uniformly loaded by floor loading of 1.5 kN/m<sup>2</sup> imposed load and 0.75 kN/m<sup>2</sup> dead load, with the worst case joist spacing of 600mm.
- For joists resisting large point loads (e.g. trimming joists), or for a more accurate evaluation of the effect of holes, refer to the design equations opposite.
- The length-height ratio for rectangular holes must be between 0.5 and 2.0.
- Spacing between hole centrelines must be at least three times the greatest dimension of either hole.
- A 40mm circular hole may be cut anywhere in the joist web.
- With the exception of holes less than 40mm in diameter, the distance between a hole centreline and the end of the joist must exceed 200mm or twice the greatest dimension of the hole, whichever is the greater.
- CUT ALL HOLES CAREFULLY, DO NOT OVERCUT OR CUT THE FLANGES.

**Design equation to calculate shear strength of a BCI® Joist with a CIRCULAR hole in its web**

$$V_{circ} = 0.75 V_{full-section} (1 - D/H)$$

where  $V_{circ}$  = Shear strength of BCI-joist with a circular hole

$V_{full-section}$  = Shear strength of same size BCI® Joist without any holes (see p. 10)

D = Diameter of hole

H = Depth of BCI® Joist

**Design equation to calculate shear strength of a BCI® Joist with a RECTANGULAR hole in its web**

$$V_{rect} = 0.5 V_{full-section} (1 - D/H) (D/W)^{0.5}$$

where  $V_{rect}$  = Shear strength of BCI® Joist with a rectangular hole

$V_{full-section}$  = Shear strength of same size BCI® Joist without any holes (see p. 10)

D = Depth of hole

W = Length of hole

H = Depth of BCI-joist

## Ground Floor Joist Design

Boise Cascade Engineered Wood Products recommends that ground floor joists are designed to improved serviceability levels to provide a floor with a similar 'feel' to an in situ or precast concrete floor construction, but this decision is at the discretion of the Building Designer. Ground floor joists are considered to be in a service class 2 environment and should be designed using the service class 2 properties given in the table on page 10.

Due to the lack of a plasterboard diaphragm on the underside of the joists, it may be necessary to install a bracing system to the bottom flange of the BCI® Joists where they are continuous over internal supports, and consequently the bottom flange will be subject to a compression force.

## Protection Against Ground Moisture

The ground cover layer should be chosen from one of the following options:

- a) 50mm of inert sand, gravel or concrete on 300 micron (1200g) polythene (1000g if PIFA branded) lapped and turned up at the edges, on 25mm sand blinding
- b) 100mm concrete on well consolidated hardcore
- c) 50mm concrete on polyethylene membrane on 50mm sand blinding

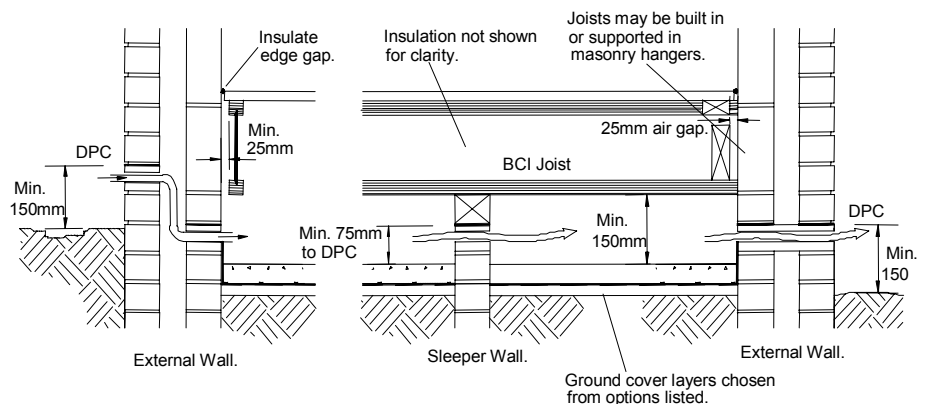

On sloping sites where external ground levels are higher than internal, the internal ground cover should fall to a suitable drainage outlet.

Under floor ventilation should be in accordance with The Building Regulations and ventilator manufacturer specifications. A minimum clear height of 150mm should be provided between the underside of the BCI® Joists and the internal ground cover.

Where protection is required against Radon gas or other ground gases specialist advice should be sought.

## Insulation

U values and insulation requirements will vary depending on the floor size and must be calculated independently for each floor construction.

Insulation can be installed in ground floor situations using three methods:

- 1) Use a rigid insulation without additional support by sitting the insulation directly on the BCI® Joist bottom flanges
- 2) Support the insulation between the joists on either a galvanised wire mesh or a breather membrane
- 3) Fix fibreboard or rigid mesh to the BCI® Joist bottom flanges and place the insulation on top

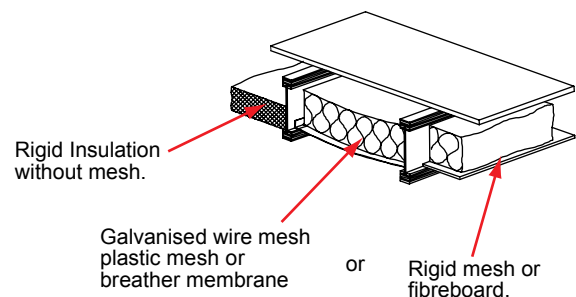

## Disabled Access

All new dwellings require a level threshold to provide easy access for the disabled. Refer to *DETR – 'Accessible thresholds in new housing; Guidance for house builders and designers'*, or *TRADA Technology – 'Level Thresholds: the timber floor solution.'*

## BCI® Joist Floor Construction to Meet the Requirements of Parts B, E and L1 (Fire, Sound and Air Leakage) of The Building Regulations

Recent changes to Part E of The Building Regulations (Resistance to the passage of sound – 2003 Edition) coupled with earlier changes to Part L1 (Conservation of fuel and power – 2002 Edition) together with the continuing need to meet the requirements of Part B (Fire safety) mean that when considering prospective floor constructions for a project it is necessary to select appropriate floor deck, joists and ceiling products that result in a floor system that meets all regulatory requirements.

### The Requirements

#### Sound Resistance

The 2003 edition of Approved Document E sets improved sound insulation standards for floors within dwellings and between dwellings, and their junctions with separating walls. In addition, separating floors between dwellings will require pre-completion testing if not constructed in accordance with Robust details<sup>[A]</sup>. The sound insulation performance that floors must achieve is shown in the table below.

| Sound Resistance Required for Floors |                                  |                          |  |  |
|--------------------------------------|----------------------------------|--------------------------|--|--|
| Floor Type                           | Sound Resistance Required        |                          | Pre-completion testing required?   | Boise Cascade Solution   |
|                                      | Airborne dB min.                 | Impact $L_n T_w$ dB max. |  |  |
| Intermediate                         | $R_w \geq 40^{[B]}$              | -                        | No   | See below for intermediate BCI® Joist floors that meet the requirement of Building Regulation E2   |
| Separating                           | $L_n T_w + C_{tr} \geq 45^{[C]}$ | $\leq 62^{[C]}$          | No – if floor constructed in accordance with Robust details.<br>Yes – if floor not constructed in accordance with Robust details | See detail below for I-joist separating floor that conforms to Robust details. Note that both floor and separating wall must be compatible Robust details to avoid pre-completion testing. Refer to 'Robust details Part – E Resistance to the passage of sound,' January 2005 |

<sup>[A]</sup> The use of Robust details by builders is subject to the terms and conditions set out by Robust Details Limited.

<sup>[B]</sup> The requirement is for a laboratory sound reduction of 40dB.

<sup>[C]</sup> The requirement is for on site sound reduction, met by either complying with Robust details or pre-completion testing.

Compliance with the sound resistance requirements for BCI® Joist floors is provided by laboratory sound tests in respect of intermediate floors, and adherence to Robust details in respect of separating floors.

#### Fire Resistance

Approved Document B to The Building Regulations requires floors to achieve the periods of fire resistance noted in the table below. Fire resistance is usually defined in three parts: structure, integrity and insulation. Broad definitions are as follows: **Structure** – the construction shall not fail during the required resistance period. **Integrity** – the construction shall not allow combustion gases or smoke to pass through during the required resistance period. **Insulation** – the construction shall not allow excessive heat to pass through during the required resistance period.

| Fire Resistance Periods for Floors                           |                                    |                           |
|--|------------------------------------|---------------------------|
| Building Type  | Floor Type                         | Required Resistance (Min) |
| House - detached, semi, terrace, not more than three storeys | Intermediate <sup>[1] [2]</sup>    | 30                        |
| Flats  | Separating                         | 60                        |
| Maisonettes  | Intermediate (within a maisonette) | 30                        |
|  | Separating (between maisonettes)   | 60                        |

For all other building uses refer to Approved Document B

<sup>[1]</sup> The intermediate floor in a 2-storey house may have a modified 1/2-hour fire resistance; 30 minute structure, 15 minutes integrity and 15 minutes insulation.

<sup>[2]</sup> The intermediate floor above a basement should have at least 1-hour fire resistance.

The walls between semi-detached or terraced houses, and between flats, are separating walls and should have at least 1-hour fire resistance.

Compliance with the fire resistance requirements for BCI® Joist floors is provided by the results of full-scale structural fire tests.

## BCI® Joist Floor Construction to Meet the Requirements of Parts B, E and L1 (Fire, Sound and Air Leakage) of The Building Regulations (continued)

### The Requirements (continued)

#### Air Leakage

Approved Document L1 (2002 Edition) requires buildings to limit unwanted air leakage, and in the absence of performance criteria refers to the use of Robust Details contained in the publication 'Limiting thermal bridging and air leakage: Robust construction details for dwellings and similar buildings'. The primary area affected with regard to floors is in their junctions with external walls and in particular masonry walls. Timber frame floors and walls remain largely unaffected. To ensure compliance with the approved Document, the Robust Details show joists supported at external walls in masonry hangers. Alternatively, a construction detail that involves building joists into the wall and sealing all air paths with silicone sealant is accepted by Regulatory Authorities subject to good site workmanship. Additionally, proprietary details that can be shown by laboratory tests to meet or exceed the air leakage performance of the silicone sealant detail may also be used.

Compliance with the air leakage requirements for BCI® Joist floors is provided by the use of either a proprietary detail (Proprietary End Cap), the silicone sealant detail, or by supporting joists in masonry hangers.

### Meeting the Requirements

The following details showing floor constructions and floor/wall junctions have been prepared to meet the current Building Regulation requirements with regard to Part B, Part E and Part L1. Each detail gives reference to relevant test data or Robust Details in validation of the performance.

### Intermediate floors

#### General Floor Construction

The diagrams and table below specify intermediate floor constructions that meet the Building Regulation requirements for Sound and Fire.

| Intermediate Floor Constructions |  |  |  |
|----------------------------------|--|--|--|
|                                  | Section Through Floor  | Layer and Material   | Justification  |
| In-1                             | <p>Floor deck.</p> <p>BCI® Joists.</p> <p>Ceiling / Absorbent Layer.</p> | <p><b>Floor Deck:</b><br/>22mm P5 Chipboard</p> <p><b>Joist:</b><br/>Any BCI® Joist 241mm or deeper at 600mm centres</p> <p><b>Ceiling/Absorbent Layer:</b><br/>15mm Type 1 plasterboard<sup>[1]</sup><br/>12.5mm Type 1 plasterboard +3mm skim<sup>[1]</sup><br/>12.5mm Type 5 fire resisting plasterboard<sup>[1]</sup><br/>(all inclusive 1 downlighter per 1.5m<sup>2</sup> floor area)</p>  | <p><b>Sound:-</b> Lab tests in accordance with BS EN ISO 140-3:1995, and expert sound consultant assessment of results.</p> <p><b>Fire:-</b> ½ hour structural fire test in accordance with BS 476-21:1987 and expert fire consultant assessment of results.</p> |
| In-2                             | <p>Floor deck.</p> <p>BCI® Joists.</p> <p>Ceiling / Absorbent Layer.</p> | <p><b>Floor Deck:</b><br/>22mm P5 Chipboard</p> <p><b>Joist:</b><br/>Any BCI® Joist 241mm or deeper at 400mm centres or greater</p> <p><b>Ceiling/Absorbent Layer:</b><br/>15mm Type 1 plasterboard<sup>[1]</sup> +1mm skim<br/>12.5mm Type 1 plasterboard<sup>[1]</sup> +4mm skim<br/>12.5mm Type 5 fire resisting plasterboard<sup>[1]</sup> +1mm skim<br/>(all inclusive 1 downlighter per 1.5m<sup>2</sup> floor area)</p>   | <p><b>Sound:-</b> Lab tests in accordance with BS EN ISO 140-3:1995, and expert sound consultant assessment of results.</p> <p><b>Fire:-</b> ½ hour structural fire test in accordance with BS 476-21:1987 and expert fire consultant assessment of results.</p> |
| In-3                             | <p>Floor deck.</p> <p>BCI® Joists.</p> <p>Ceiling / Absorbent Layer.</p> | <p><b>Floor Deck:</b><br/>22mm P5 Chipboard or 22mm cement bonded particle board, or any board with a surface mass of 15kg/m<sup>2</sup></p> <p><b>Joist:</b><br/>Any BCI® Joist at any centres</p> <p><b>Ceiling/Absorbent Layer:</b><br/>15mm Type 1 plasterboard<sup>[1]</sup><br/>12.5mm Type 1 plasterboard<sup>[1]</sup> +3mm skim<br/>12.5mm Type 5 fire resisting plasterboard<sup>[1]</sup><br/>plus<br/>100mm mineral wool insulation min density 10kg/m<sup>3</sup></p> | <p><b>Sound:-</b> Approved Document E clause 5.23 deemed to satisfy construction.</p> <p><b>Fire:-</b> ½ hour structural fire test in accordance with BS 476-21:1987 and expert fire consultant assessment of results.</p>                                       |

<sup>[1]</sup> Plasterboard to have a minimum surface mass of 10kg/m<sup>2</sup>.



## BCI® Joist Floor Construction to Meet the Requirements of Parts B, E and L1 (Fire, Sound and Air Leakage) of The Building Regulations (continued)

### Junction with Masonry Separating Wall

The following construction meets The Building Regulation requirements for Sound, Fire and Air Leakage.

| Intermediate Floor Junction with Masonry Separating Wall   |   |  |
|--|---|--|
| InMs-1   | InMs-2  | InMs-3   |
| <p>Wall construction to be in accordance with Robust details E-WM-1,2,3,4,5, or 6.</p> <p>Floor to comply with regulation E2 selected from Boise Cascade intermediate floor table.</p> <p>Proprietary End Cap snap fitted to end of BCI® Joist. Ensure good mortar key between masonry, End Cap and joist web.</p> | <p>Mortar joint struck and recessed and filled with silicone sealant.</p> <p>Ply/OSB filler pieces with all joints filled with silicone sealant.</p> <p>Fix fillers to joist using a min. of 3-No nails driven through and clenched.</p> <p>90mm min. bearing providing lateral wall restraint.</p> | <p>BCI® Joists supported in masonry hangers</p>  |
| Justification  |   |  |
| <p><b>Sound:-</b> Accepted as Robust detail, Appendix A by virtue of meeting air leakage requirements of Approved Document L1.</p> <p><b>Fire:-</b> 1hr fire resistance – expert fire consultant assessment.</p> <p><b>Air Leakage:-</b> Meets air leakage requirements of Approved Document L1.</p>               | <p><b>Sound:-</b> Robust detail, Appendix A</p> <p><b>Fire:-</b> To be assessed by Building Designer.</p> <p><b>Air Leakage:-</b> Meets air leakage requirements of Approved Document L1.</p>   | <p><b>Sound:-</b> Robust detail</p> <p><b>Fire:-</b> 1hr fire resistance from uninterrupted masonry wall.</p> <p><b>Air Leakage:-</b> Robust detail.</p> |

### Junction with Masonry External Wall

| Intermediate Floor Junction with Masonry Exterior Wall   |   |   |
|--|---|---|
| InMe-1   | InMe-2  | InMe-3  |
| <p>Floor to comply with regulation E2 selected from Boise Cascade Intermediate Floor table.</p> <p>Proprietary End Cap snap fitted to end of BCI® Joist. Ensure good mortar key between masonry, End Cap and joist web.</p>                                  | <p>Mortar joint struck and recessed and filled with silicone sealant.</p> <p>Ply/OSB filler pieces with all joints filled with silicone sealant.</p> <p>Fix fillers to joist using a min. of 3-No nails driven through and clenched.</p> <p>90mm min. bearing providing lateral wall restraint.</p> | <p>BCI® Joists supported in masonry hangers</p>   |
| Justification  |   |   |
| <p><b>Sound:-</b> No specific requirement.</p> <p><b>Fire:-</b> ½ hour required. 1 hour fire resistance to outside is provided by expert fire consultant assessment.</p> <p><b>Air Leakage:-</b> Meets air leakage requirements of Approved Document L1.</p> | <p><b>Sound:-</b> No specific requirement.</p> <p><b>Fire:-</b> ½ hour fire resistance provided by ceiling plasterboard.</p> <p><b>Air Leakage:-</b> Meets air leakage requirements of Approved Document L1.</p>  | <p><b>Sound:-</b> No specific requirement.</p> <p><b>Fire:-</b> 1hr fire resistance from uninterrupted masonry wall.</p> <p><b>Air Leakage:-</b> Robust detail.</p> |

## BCI® Joist Floor Construction to Meet the Requirements of Parts B, E and L1 (Fire, Sound and Air Leakage) of The Building Regulations (continued)

### Junction with Timber Frame Separating Wall

The following construction meets The Building Regulation requirements for Sound, Fire and Air Leakage.

#### Intermediate Floor Junction with Timber Frame Separating Wall

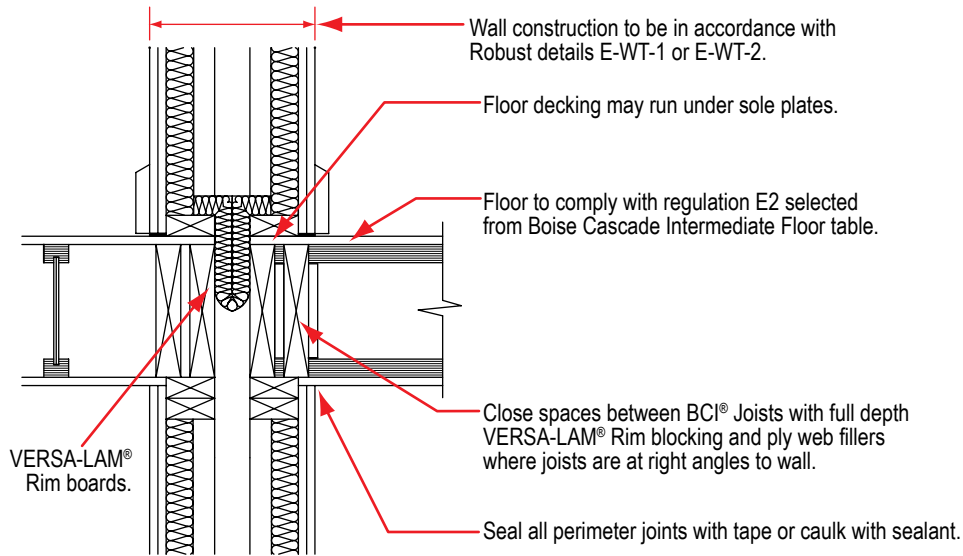

#### Justification

Sound:- Robust detail    Fire:- TRADA Technology 'Timber frame construction Chapter 5'  
 Air leakage:- Meets air leakage requirements of Approved Document L1

### Junction with Timber Frame External Wall

The following construction meets The Building Regulation requirements for Sound, Fire and Air Leakage.

#### Intermediate Floor Junction with Timber Frame External Wall

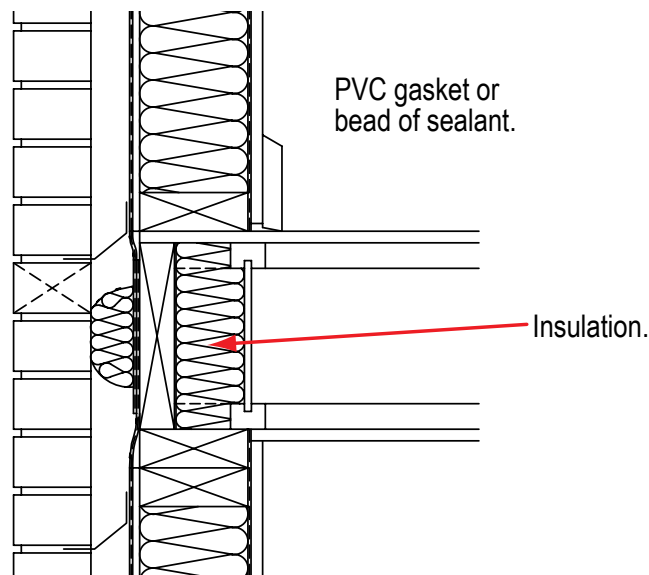

#### Justification

Sound:- No specific requirement    Fire:- Generic timber frame detail    Air leakage:- Robust Detail

## BCI® Joist Floor Construction to Meet the Requirements of Parts B, E and L1 (Fire, Sound and Air Leakage) of The Building Regulations (continued)

### Separating Floor Construction

#### General Floor Construction

The diagram and table below specifies separating floor constructions that meet the Building Regulation requirements for Sound and Fire.

| Separating Floor Construction   |   |   |  |
|---|---|---|--|
| Se-1  |   |   |  |
|   | Section Through Floor   | Layer and Material  | Justification  |
| Se-1  | <p>Floating floor.</p> <p>Floor decking.</p> <p>Joists.</p> <p>Ceiling.</p> | <p><b>Floating Layer:</b><br/>                     18mm (min) t&amp;g flooring board<br/>                     19mm plasterboard (13.5kg/m<sup>2</sup>)<br/>                     70mm resilient composite deep battens<br/>                     25mm mineral wool between battens</p>  | <p><b>Sound:-</b> Robust detail E-FT-1. Floating layer as described or alternative that must achieve lab performance of <math>\Delta R_w + C_{tr} = 13dB</math> and <math>\Delta L_w = 15dB</math>.</p> <p>Deck and joist layer as described.</p>  |
|   |   | <p><b>Floor Deck:</b><br/>                     15mm min floor deck</p> <p><b>Joist:</b><br/>                     Any BCI® Joist 241mm or deeper</p> <p><b>Ceiling/Absorbent Layer:</b><br/>                     Metal resilient bars at 400mm c/c<br/>                     2 layers plasterboard min 23kg/m<sup>2</sup>, typically 19mm Type 1 plank and 12.5mm Type 1 plasterboard</p> | <p>Ceiling/Absorbent layer as described or alternative that must achieve lab performance of <math>\Delta R_w + C_{tr} = 17dB</math> and <math>\Delta L_w = 16dB</math>.</p> <p><b>Fire:-</b> 1 hour structural fire test in accordance with BS 476-21:1987 and expert fire consultant assessment of results.</p> |
| <p>Notes: 1/. This is Robust detail 'Separating Floor - Timber I-joists E-FT-1'.<br/>                     2/. This floor construction would not require pre-completion testing if used in conjunction with Robust detail 'Separating Walls – Timber Frame EW-T-1 or EW-T-2'.<br/>                     3/. This floor construction would require pre-completion testing if used in conjunction with either a Robust detail masonry wall, or any other non Robust detail masonry wall or timber frame wall.</p> |   |   |  |

#### Junction with Timber Frame Separating Wall

The following construction meets The Building Regulation requirements for Sound, Fire and Air Leakage.

| Separating Floor Junction with Timber Frame Separating Wall  |  |
|--|--|
| SeTs-1   |  |
|  |  |
| <p><b>Sound:-</b> Robust detail    <b>Fire:-</b> TRADA Technology 'Timber frame construction Chapter 5'<br/> <b>Air leakage:-</b> Meets air leakage requirements of Approved Document L1</p> |  |

## BCI® Joist Floor Construction to Meet the Requirements of Parts B, E and L1 (Fire, Sound and Air Leakage) of The Building Regulations (continued)

### Junction with Timber Frame External Wall

The following construction meets The Building Regulation requirements for Sound, Fire and Air Leakage.

### Separating Floor Junction with Timber Frame External Wall

SeTe-1

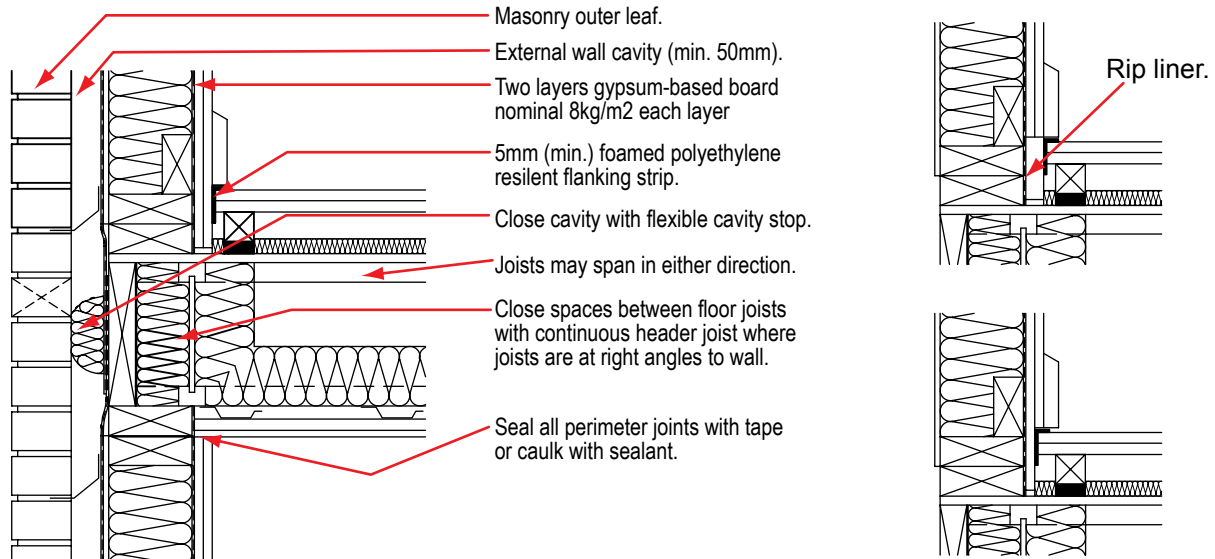

Sound:- Robust detail E-FT-1 Fire:- TRADA Technology 'Timber frame construction Chapter 5 Air leakage:- Robust detail

### Junction with Masonry Walls

There is currently no authoritative guidance on satisfying the requirements of Approved Document E (Sound) with regard to I-joist separating floors and their junctions with masonry walls. Generic details are shown below, but specialist acoustic advice should be sought where this type of construction is proposed. Pre-completion sound testing will be required.

### Separating Floor Junction with Masonry Wall

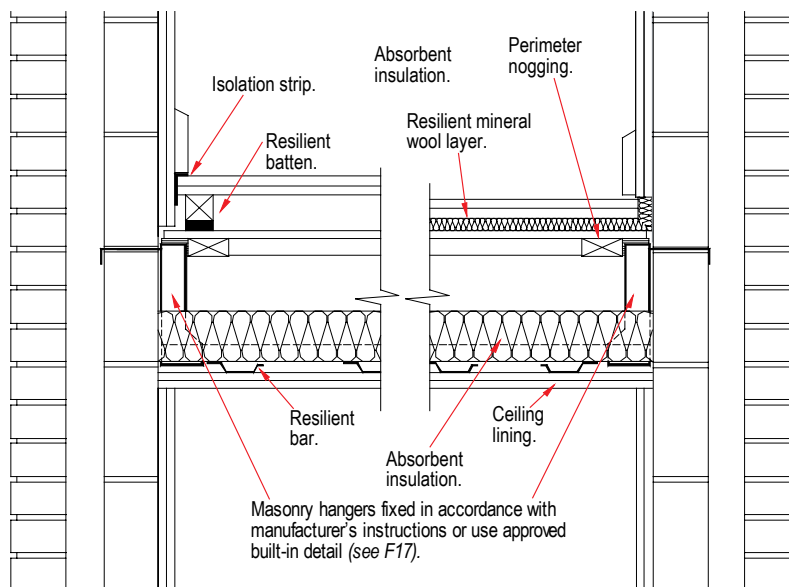

Generic detail only, seek specialist advice for sound reduction performance.



## Roof Design Criteria

BCI® Joists can be used to create open roof voids in buildings by acting as free-spanning rafters between a ridge beam at the roof apex and the wallplate at eaves level.

BCI® Joist suppliers involved in roof applications assume a role similar to that of the trussed rafter designer, as outlined in BS5268-3:1998, clauses 6, 7 and 11. The Building Designer remains responsible for the roof design, including specification of all holding down fixings at support positions, and the stability and wind bracing systems, unless otherwise agreed or a roof designer has been employed. I-Joist roofs should be braced, or arranged, to form a coherent structure. The bracing can be in the form of a structural diaphragm (sarking) or triangulating members, the specification of which remains the responsibility of the Building Designer.

BCI® Joists are designed for roof applications using the principles of BS5268-2:2002 and the joist properties contained in BBA Certificate 99/3620. In general, it can be assumed that well-ventilated roofs in the UK will achieve a Service Class 2 moisture condition. Uniformly distributed dead and imposed loads will be assumed across the whole roof unless otherwise directed. For small buildings, as detailed in BS6399-3, imposed loads (snow loading) will generally be taken as  $0.75 \text{ kN/m}^2$  (measured on plan) up to pitches of  $30^\circ$ , reducing linearly to zero at  $60^\circ$  pitch, unless specific guidance in the aforementioned code would suggest alternative imposed roof loadings may apply. Snow loading will be assumed to be of medium term duration. Dead loads from coverings may be taken from the schedule of standard tile weights tabulated to the right.

### Schedule of Roof Covering Dead Loads

| Tile Manufacturer and Product | Weight on Slope<br>(inc. SW allowance<br>of $110 \text{ N/m}^2$ ) |
|-------------------------------|---|
| Marley Modern                 | $659 \text{ N/m}^2$   |
| Marley Plain                  | $973 \text{ N/m}^2$   |
| Marley Bold Roll              | $630 \text{ N/m}^2$   |
| Redland Cambrian              | $306 \text{ N/m}^2$   |
| Redland Renown                | $565 \text{ N/m}^2$   |
| Redland Rosemary              | $767 \text{ N/m}^2$   |
| Thatching (305mm Thick)       | $518 \text{ N/m}^2$   |

In practice, roof dead loads are often categorised as either light, standard or heavy, these being  $0.434 \text{ kN/m}^2$ ,  $0.685 \text{ kN/m}^2$  or  $0.880 \text{ kN/m}^2$ , representing fibre-cement, concrete interlocking and plain concrete-type tiles, respectively. These values are measured along the rafter slope and include an allowance of  $0.11 \text{ kN/m}^2$  for felt, battens and rafter self weight.

Since ceiling finishes may often be directly applied to the underside of BCI® Joists used to create open roof voids, Boise Cascade Engineered Wood Products Engineering recommends that BCI® rafters be designed with a  $0.25 \text{ kN/m}^2$  ceiling dead load, including further allowance for self weight of the rafter and a deflection limit of  $0.3\% \times \text{span}$  under the total (dead + imposed) load. On this basis, maximum rafter spans are shown on pages 37 and 38 for a range of roof pitches for either light, standard or heavy roof coverings.

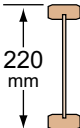
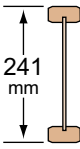
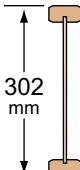
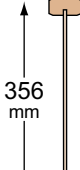
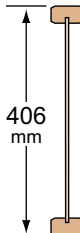

## Roof Rafter Span Tables

| Joist Depth   | Joist Series | Maximum Rafter Spans (m) @ 400mm c/c (Medium duration loading, $k_3 = 1.25$ )             |       |      |       |      |  |       |      |       |      |   |       |      |       |      |
|---|--------------|---|-------|------|-------|------|--|-------|------|-------|------|---|-------|------|-------|------|
|   |              | Lightweight Tile Loading<br>(0.434kN/m <sup>2</sup> dead + 0.75kN/m <sup>2</sup> imposed) |       |      |       |      | Standard Tile Loading<br>(0.685kN/m <sup>2</sup> dead + 0.75kN/m <sup>2</sup> imposed) |       |      |       |      | Heavy Tile Loading<br>(0.880kN/m <sup>2</sup> dead + 0.75kN/m <sup>2</sup> imposed) |       |      |       |      |
|   |              | 15°   | 22.5° | 30°  | 37.5° | 45°  | 15°  | 22.5° | 30°  | 37.5° | 45°  | 15°   | 22.5° | 30°  | 37.5° | 45°  |
|    | 4500s        | 4.80  | 4.68  | 4.51 | 4.30  | 4.02 | 4.48   | 4.37  | 4.21 | 4.00  | 3.74 | 4.28  | 4.17  | 4.02 | 3.82  | 3.57 |
|   | 60s          | 5.56  | 5.45  | 5.28 | 5.11  | 4.78 | 5.24   | 5.13  | 4.97 | 4.73  | 4.42 | 5.04  | 4.93  | 4.75 | 4.51  | 4.21 |
|   | 90s          | 6.39  | 6.26  | 6.07 | 6.02  | 5.62 | 6.02   | 5.89  | 5.71 | 5.55  | 5.18 | 5.79  | 5.66  | 5.48 | 5.28  | 4.93 |
|    | 4500s        | 5.17  | 5.06  | 4.91 | 4.68  | 4.38 | 4.87   | 4.75  | 4.57 | 4.34  | 4.06 | 4.65  | 4.53  | 4.36 | 4.15  | 3.87 |
|   | 6000s        | 5.42  | 5.31  | 5.15 | 4.96  | 4.64 | 5.12   | 5.01  | 4.84 | 4.59  | 4.29 | 4.92  | 4.79  | 4.61 | 4.38  | 4.10 |
|   | 60s          | 5.89  | 5.77  | 5.60 | 5.47  | 5.12 | 5.55   | 5.43  | 5.26 | 5.05  | 4.72 | 5.33  | 5.22  | 5.05 | 4.82  | 4.50 |
|   | 90s          | 6.81  | 6.67  | 6.48 | 6.49  | 6.07 | 6.42   | 6.28  | 6.09 | 5.97  | 5.58 | 6.17  | 6.03  | 5.84 | 5.68  | 5.30 |
|  | 4500s        | 6.14  | 6.01  | 5.83 | 5.74  | 5.37 | 5.80   | 5.67  | 5.49 | 5.30  | 4.95 | 5.57  | 5.45  | 5.27 | 5.05  | 4.72 |
|   | 6000s        | 6.45  | 6.31  | 6.12 | 6.08  | 5.68 | 6.08   | 5.95  | 5.76 | 5.61  | 5.23 | 5.85  | 5.72  | 5.53 | 5.34  | 4.98 |
|   | 60s          | 7.06  | 6.92  | 6.71 | 6.72  | 6.31 | 6.66   | 6.52  | 6.31 | 6.22  | 5.80 | 6.40  | 6.26  | 6.06 | 5.92  | 5.52 |
|   | 90s          | 8.13  | 7.97  | 7.73 | 7.76  | 7.43 | 7.67   | 7.51  | 7.27 | 7.21  | 6.81 | 7.37  | 7.21  | 6.97 | 6.89  | 6.46 |
|  | 6000s        | 7.29  | 7.14  | 6.93 | 6.94  | 6.54 | 6.88   | 6.73  | 6.52 | 6.45  | 6.02 | 6.62  | 6.47  | 6.26 | 6.13  | 5.72 |
|   | 60s          | 8.04  | 7.87  | 7.63 | 7.65  | 7.31 | 7.58   | 7.42  | 7.18 | 7.11  | 6.71 | 7.29  | 7.13  | 6.90 | 6.80  | 6.37 |
|   | 90s          | 9.23  | 9.02  | 8.78 | 8.80  | 8.57 | 8.71   | 8.52  | 8.25 | 8.18  | 7.83 | 8.36  | 8.18  | 7.92 | 7.82  | 7.42 |
|  | 6000s        | 8.05  | 7.88  | 7.65 | 7.66  | 7.32 | 7.60   | 7.43  | 7.20 | 7.12  | 6.72 | 7.31  | 7.14  | 6.91 | 6.81  | 6.38 |
|   | 60s          | 8.90  | 8.72  | 8.46 | 8.47  | 8.21 | 8.40   | 8.22  | 7.96 | 7.88  | 7.51 | 8.08  | 7.90  | 7.64 | 7.53  | 7.13 |
|   | 90s          | 10.19   | 9.99  | 9.69 | 9.71  | 9.57 | 9.61   | 9.41  | 9.11 | 9.03  | 8.73 | 9.24  | 9.03  | 8.74 | 8.63  | 8.26 |

### Design Notes :

- 1 - All spans quoted are 'engineering spans' measured on plan between centres of bearings.
- 2 - Linear interpolation may be used for intermediate roof pitches between those tabulated.
- 3 - Spans assume rafters are restrained via battens at centres no greater than 400mm.
- 4 - Dead loads quoted are measured on slope and allow for standard fibre-cement, concrete interlocking and plain concrete tiles respectively plus felt, battens, rafter self-weight and plasterboard ceiling. **A ceiling dead load allowance of 0.25kN/m<sup>2</sup> has been assumed.**
- 5 - Imposed load assumed is 0.75kN/m<sup>2</sup> (measured on plan) up to 30° pitch, reducing linearly thereafter to zero at 60° pitch.
- 6 - All spans quoted relate to medium-term load duration. Refer to Boise Cascade Engineered Wood Products Engineering for long-term loading conditions.
- 7 - Deflection limited to 0.3% of the span.

## Roof Rafter Span Tables

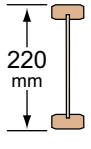
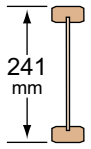
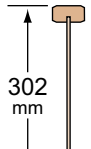
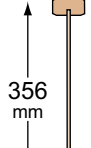
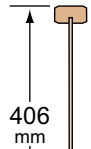
| Joist Depth   | Joist Series | Maximum Rafter Spans (m) @ 600mm c/c (Medium duration loading, $k_3 = 1.25$ )             |       |      |       |      |  |       |      |       |      |   |       |      |       |      |
|---|--------------|---|-------|------|-------|------|--|-------|------|-------|------|---|-------|------|-------|------|
|   |              | Lightweight Tile Loading<br>(0.434kN/m <sup>2</sup> dead + 0.75kN/m <sup>2</sup> imposed) |       |      |       |      | Standard Tile Loading<br>(0.685kN/m <sup>2</sup> dead + 0.75kN/m <sup>2</sup> imposed) |       |      |       |      | Heavy Tile Loading<br>(0.880kN/m <sup>2</sup> dead + 0.75kN/m <sup>2</sup> imposed) |       |      |       |      |
|   |              | 15°   | 22.5° | 30°  | 37.5° | 45°  | 15°  | 22.5° | 30°  | 37.5° | 45°  | 15°   | 22.5° | 30°  | 37.5° | 45°  |
|    | 4500s        | 4.17  | 4.09  | 3.97 | 3.92  | 3.66 | 3.93   | 3.85  | 3.73 | 3.61  | 3.38 | 3.77  | 3.69  | 3.57 | 3.44  | 3.21 |
|   | 60s          | 4.81  | 4.71  | 4.57 | 4.59  | 4.33 | 4.53   | 4.44  | 4.30 | 4.25  | 3.97 | 4.35  | 4.26  | 4.12 | 4.04  | 3.77 |
|   | 90s          | 5.52  | 5.41  | 5.25 | 5.27  | 5.07 | 5.20   | 5.09  | 4.93 | 4.90  | 4.64 | 4.99  | 4.88  | 4.73 | 4.67  | 4.39 |
|    | 4500s        | 4.47  | 4.38  | 4.25 | 4.25  | 3.98 | 4.22   | 4.13  | 4.00 | 3.91  | 3.66 | 4.05  | 3.96  | 3.83 | 3.72  | 3.48 |
|   | 6000s        | 4.69  | 4.60  | 4.46 | 4.48  | 4.21 | 4.42   | 4.33  | 4.19 | 4.13  | 3.86 | 4.25  | 4.15  | 4.02 | 3.93  | 3.67 |
|   | 60s          | 5.09  | 4.99  | 4.85 | 4.86  | 4.62 | 4.79   | 4.69  | 4.55 | 4.51  | 4.23 | 4.60  | 4.50  | 4.36 | 4.30  | 4.02 |
|   | 90s          | 5.88  | 5.76  | 5.60 | 5.62  | 5.46 | 5.53   | 5.42  | 5.25 | 5.22  | 4.98 | 5.31  | 5.20  | 5.03 | 4.98  | 4.71 |
|  | 4500s        | 5.32  | 5.21  | 5.06 | 5.07  | 4.85 | 5.01   | 4.91  | 4.75 | 4.71  | 4.44 | 4.82  | 4.71  | 4.56 | 4.50  | 4.21 |
|   | 6000s        | 5.58  | 5.47  | 5.31 | 5.32  | 5.12 | 5.26   | 5.15  | 4.99 | 4.95  | 4.69 | 5.05  | 4.94  | 4.78 | 4.72  | 4.45 |
|   | 60s          | 6.11  | 5.99  | 5.81 | 5.83  | 5.68 | 5.76   | 5.64  | 5.46 | 5.42  | 5.18 | 5.53  | 5.41  | 5.24 | 5.17  | 4.91 |
|   | 90s          | 7.02  | 6.89  | 6.69 | 6.72  | 6.64 | 6.61   | 6.48  | 6.28 | 6.23  | 6.05 | 6.35  | 6.21  | 6.02 | 5.95  | 5.72 |
|  | 6000s        | 6.32  | 6.19  | 6.00 | 6.02  | 5.88 | 5.95   | 5.83  | 5.65 | 5.60  | 5.37 | 5.72  | 5.60  | 5.42 | 5.35  | 5.09 |
|   | 60s          | 6.96  | 6.82  | 6.61 | 6.64  | 6.55 | 6.56   | 6.42  | 6.22 | 6.17  | 5.97 | 6.30  | 6.16  | 5.97 | 5.89  | 5.65 |
|   | 90s          | 7.98  | 7.82  | 7.59 | 7.63  | 7.54 | 7.51   | 7.36  | 7.13 | 7.08  | 6.91 | 7.21  | 7.06  | 6.83 | 6.76  | 6.56 |
|  | 6000s        | 6.97  | 6.83  | 6.63 | 6.65  | 6.56 | 6.58   | 6.44  | 6.23 | 6.18  | 5.99 | 6.32  | 6.18  | 5.98 | 5.90  | 5.67 |
|   | 60s          | 7.71  | 7.56  | 7.33 | 7.35  | 7.26 | 7.27   | 7.12  | 6.89 | 6.83  | 6.67 | 6.99  | 6.83  | 6.61 | 6.53  | 6.32 |
|   | 90s          | 8.81  | 8.64  | 8.38 | 8.42  | 8.32 | 8.30   | 8.13  | 7.88 | 7.82  | 7.63 | 7.97  | 7.79  | 7.55 | 7.46  | 7.24 |

**Design Notes :**

- All spans quoted are 'engineering spans' measured on plan between centres of bearings.
- Linear interpolation may be used for intermediate roof pitches between those tabulated.
- Spans assume rafters are restrained via battens at centres no greater than 400mm.
- Dead loads quoted are measured on slope and allow for standard fibre-cement, concrete interlocking and plain concrete tiles respectively plus felt, battens, rafter self-weight and plasterboard ceiling. **A ceiling dead load allowance of 0.25kN/m<sup>2</sup> has been assumed.**
- Imposed load assumed is 0.75kN/m<sup>2</sup> (measured on plan) up to 30° pitch, reducing linearly thereafter to zero at 60° pitch.
- All spans quoted relate to medium-term load duration. Refer to Boise Cascade Engineered Wood Products Engineering for long-term loading conditions.
- Deflection limited to 0.3% of the span.

**FOR INSTALLATION STABILITY -**  
See section on temporary BCI® Joist  
bracing details given earlier

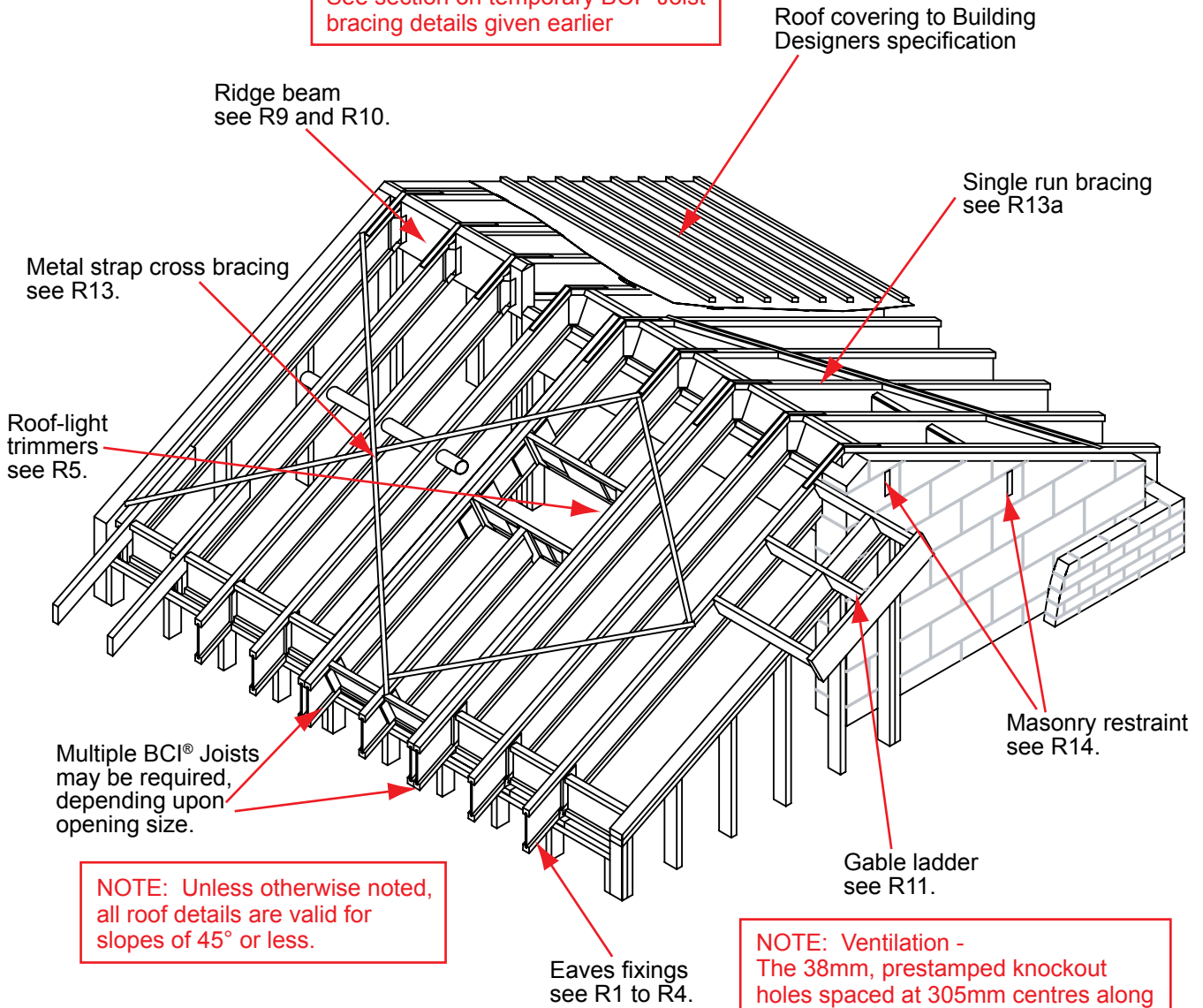

**NOTE:** Unless otherwise noted, all roof details are valid for slopes of 45° or less.

**NOTE:** Bracing is shown for illustrative purposes only. The Building Designer remains responsible for specifying all bracing to achieve roof stability.

**NOTE:** Ventilation - The 38mm, prestamped knockout holes spaced at 305mm centres along the BCI® Joist may all be knocked out and used for ventilation





## R1 Bevel plate eave details

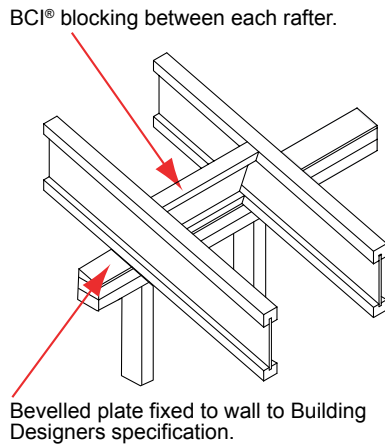

## R1a Bevel plate eaves detail (timber overhang)

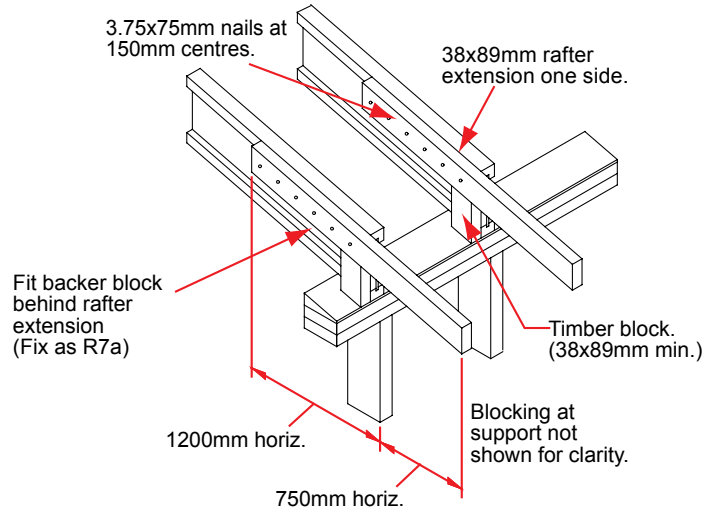

## R2 Birdsmouth eaves detail

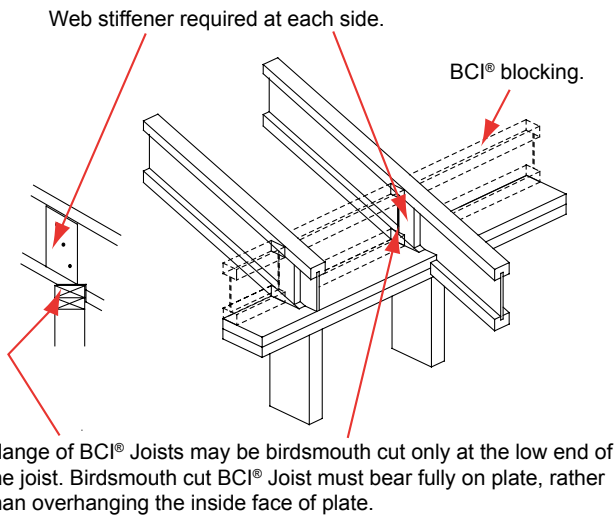

## R3 Metal connector eaves detail

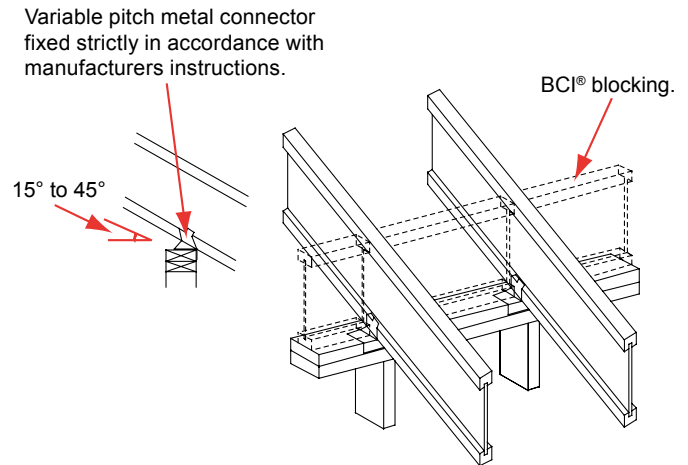

## R4 Roof eaves & floor junction

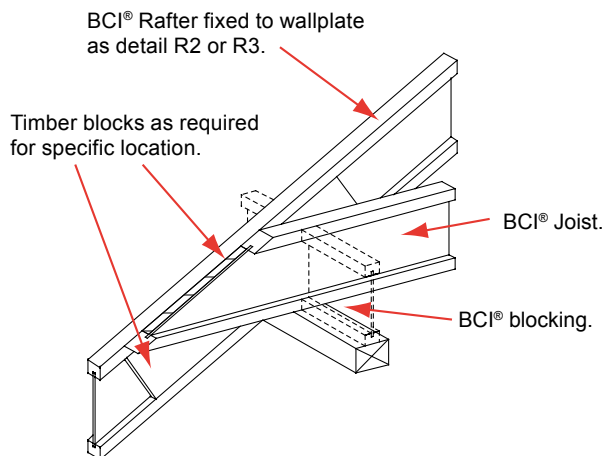

## R5 Roof-light trimming

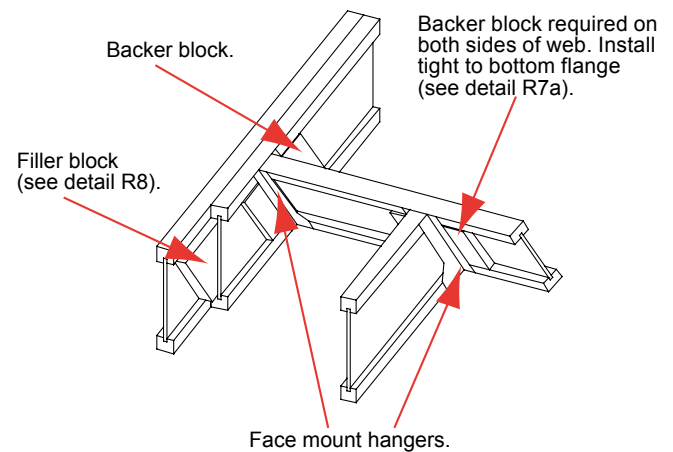

## R6 Web stiffener attachment

Small gap: 3mm min., 50mm max.

| Joist Depth | Fixings         |
|-------------|-----------------|
| 220         | 2 - 3.35 x 65mm |
| 241         | 2 - 3.35 x 65mm |
| 302         | 3 - 3.35 x 65mm |
| 356         | 5 - 3.35 x 65mm |
| 406         | 6 - 3.35 x 65mm |

Note: Use 3.75x90mm nails for 90s Series Joists

Tight fit to bottom

OSB or Plywood Web Stiffener:

|              |              |
|--------------|--------------|
| 4500s Series | 18x60mm min. |
| 6000s Series | 22x60mm min. |
| 60s Series   | 25x60mm min. |
| 90s Series   | 38x60mm min. |

Note: Web stiffeners are not required for BCI® Joists unless used in hangers that do not extend up to restrain the top flange of the BCI® Joist or as required by design.

## R7 Backer block application

Note: Fix backer block using 8-No 3.35x65mm nails clenched (see detail R7a). Use 3.35x90mm nails for 90s Series joist.

Face mount joist hanger.

Tight fit.

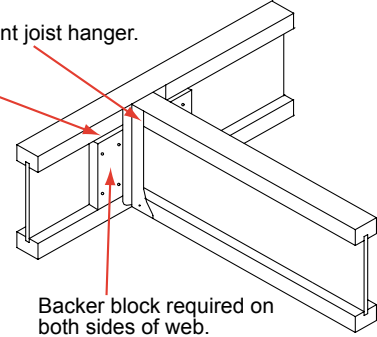

Backer block required on both sides of web.

## R7a Backer block (fixing & specification)

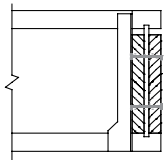

3.35x65mm nails clenched (3.35x90mm nails for 90s Series Joists).

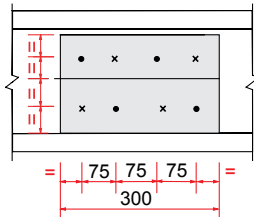

• Denotes nails from near face.  
x Denotes nails from far face.

Where nails are clenched, all nails can be driven from near side.

| Series | Backer Block Thickness  | Depth | Backer Block Depths |
|--------|-------------------------|-------|---------------------|
| 4500s  | 18mm wood panel         | 220mm | 122mm               |
| 6000s  | 25mm wood panel         | 241mm | 147mm               |
| 60s    | 25mm wood panel         | 302mm | 219mm               |
| 90s    | 18mm + 22mm wood panels | 356mm | 269mm               |
|        |                         | 406mm | 319mm               |

## R8 Filler block application

Fix 2-ply BCI® Joists together using filler blocks at all bearing points, at incoming load positions and at max 3.6m centres (see R8b).

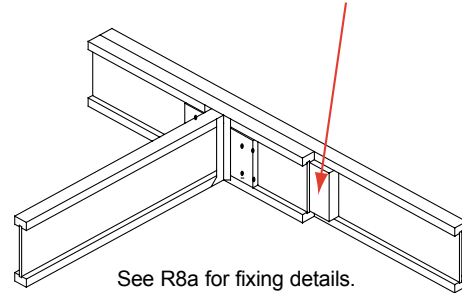

See R8a for fixing details.

## R8a Filler block (fixing & specification)

Gap required to avoid forced fit.

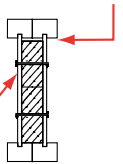

3.35x65mm nails clenched (3.35x90mm nails for 90s Series Joists).

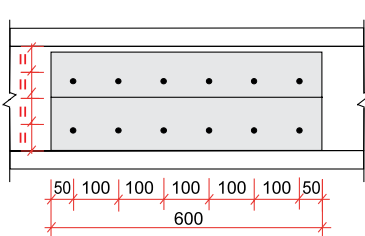

| Series | Filler Block Thickness | Joist Depth | Filler Block Depths |
|--------|------------------------|-------------|---------------------|
| 4500s  | 35mm Timber            | 220mm       | 122mm               |
| 6000s  | 47mm Timber            | 241mm       | 147mm               |
| 60s    | 47mm Timber            | 302mm       | 97mm + 122mm        |
| 90s    | 75mm Timber            | 356mm       | 122mm + 147mm       |
|        |                        | 406mm       | 147mm + 172mm       |

## R8b Intermediate filler blocks

Note: Maximum spacing between filler blocks to be 3.6 metres. Intermediate filler blocks should be installed between bearing and incoming load positions.

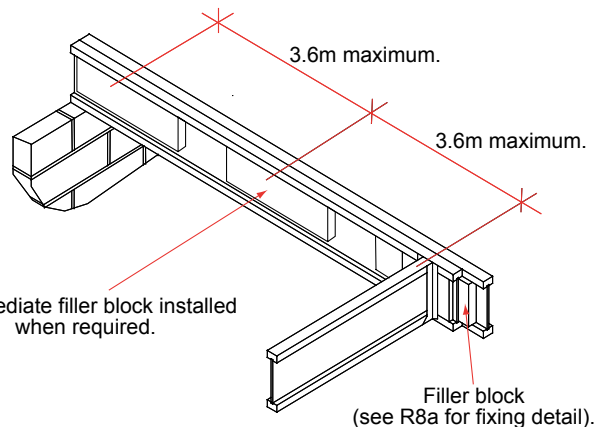

Intermediate filler block installed when required.

Filler block (see R8a for fixing detail).

## R8c Continuous filler block

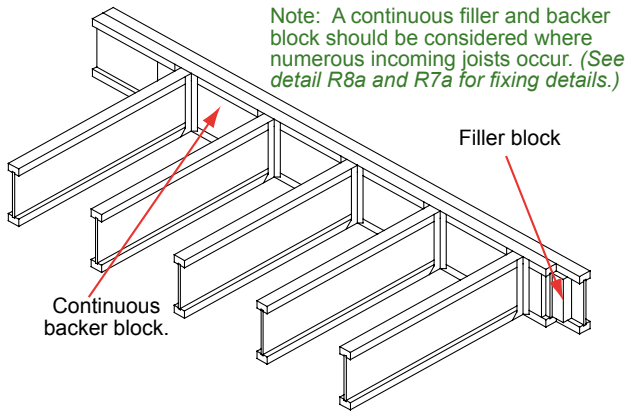

## R9 Downstand ridge beam

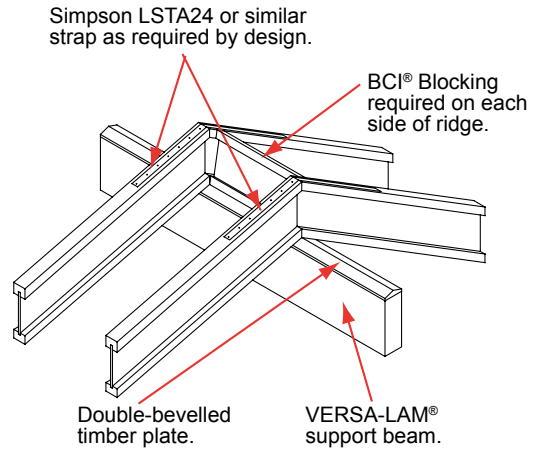

## R10 Flush ridge beam

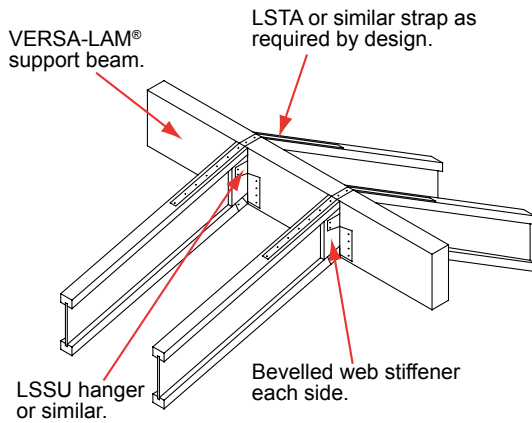

## R11 Gable ladder

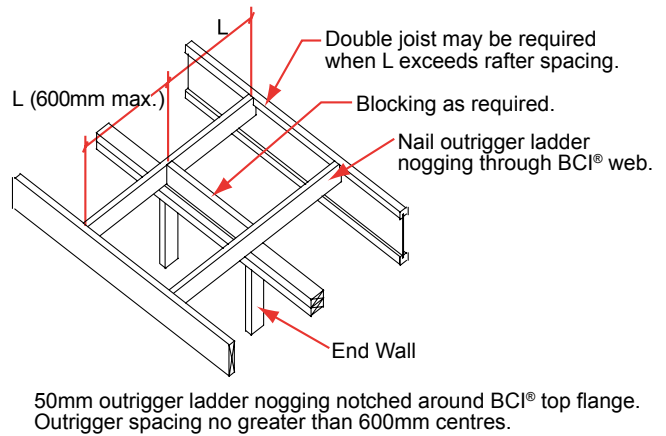

## R12 Raised ceiling junction (BCI®)

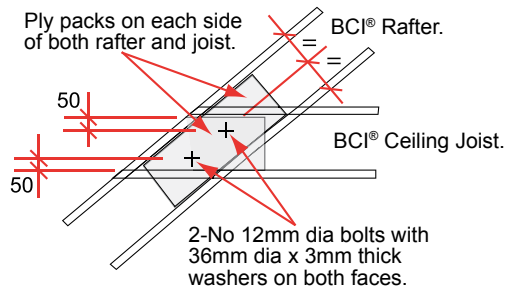

## R12a Raised ceiling junction (timber)

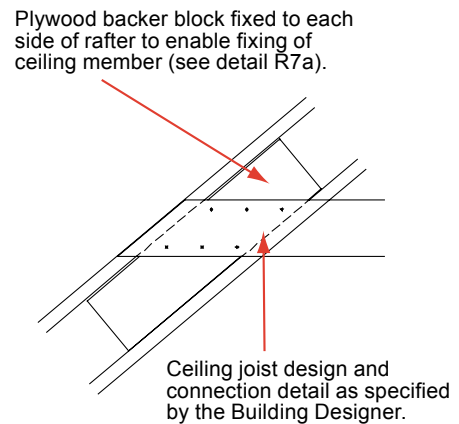

## R13 Metal strap cross bracing

Cross bracing formed using 1.0mm Steel Fixing Straps fixed to top of BCI® rafters using 3.75x32mm square twist nails (2-No per crossing).

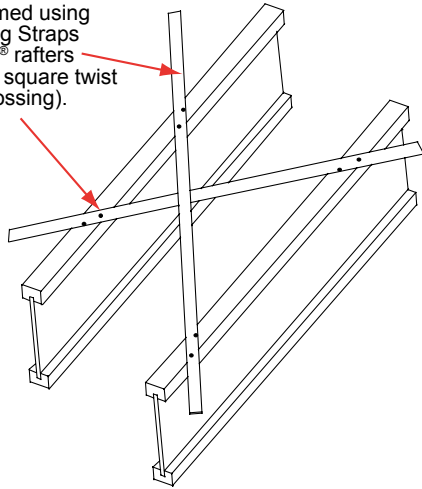

Note: The Building Designer is responsible for the arrangement and quantity of bracing to provide roof stability.

## R13a Single run bracing

35x72mm nogging.

BCI® Rafter.

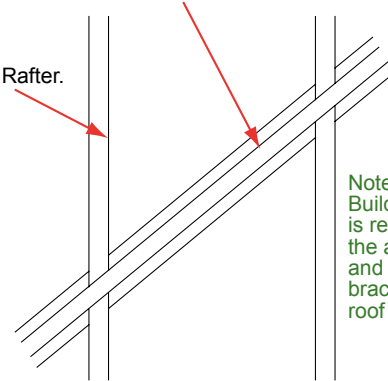

Note: The Building Designer is responsible for the arrangement and quantity of bracing to provide roof stability.

Roof stability provided by installing 35x72mm timber noggings between the rafters, cut to ensure a tight fit. Secure to rafters using 1-No 3.35x65mm lg nail per end. Continuity of bracing provided by installing 1.0mm MS Fixing Strip over noggings, nailed continuously. Bracing to be installed at approximately 45 deg to rafters on the roof slope.

## R14 Masonry wall restraint

35x145mm C16 noggings to be fixed tightly between BCI® Joists and also between Joist and wall.

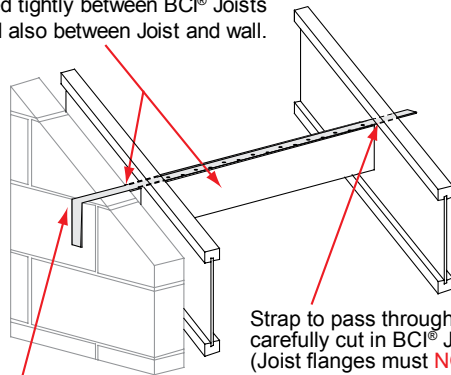

Strap to pass through slot carefully cut in BCI® Joist web (Joist flanges must NOT be cut).

Restraint strap to be fixed to uncut block.

## R15 Dormer construction

Dormer construction to Building Designers specification.

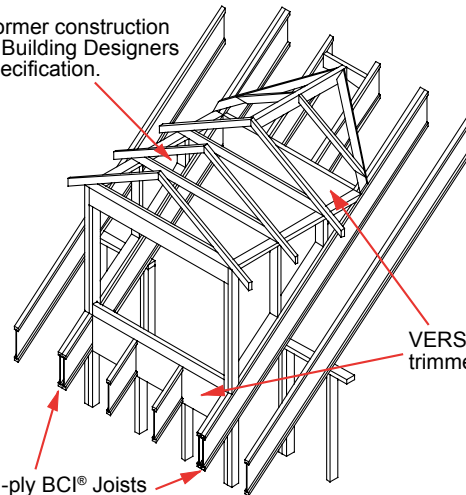

VERSA-LAM® trimmers.

Multi-ply BCI® Joists under dormer cheeks.

## R16 Flat roof over-hanging eaves

Rimboard fixed to each joist using 1-No 3.35 x 65 lg galv (or improved) wire nail to each joist flange.

Additional fixing to rimboard at max 2.0m centres comprising of 2-No framing anchors and plywood backers.

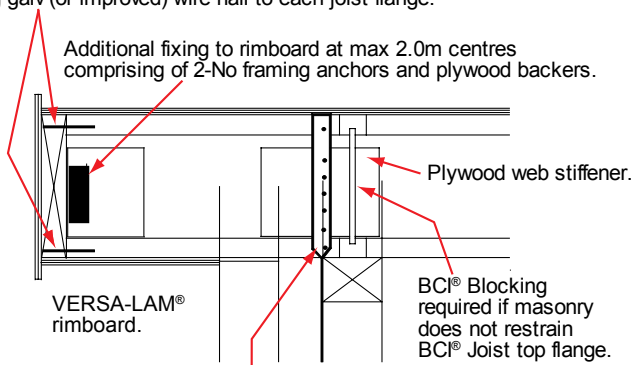

BCI® Blocking required if masonry does not restrain BCI® Joist top flange.

Holding-down strap by Builder to Building Designers specification.

Roof covering and gutter details as specified by the Building Designer.

## R17 Flat roof parapet eaves

Parapet wall.

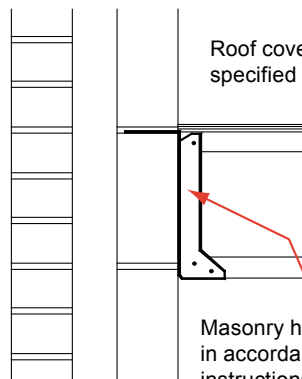

Roof covering and gutter details as specified by the Building Designer.

Masonry hanger installed into wall in accordance with manufacturer's instructions.

The Builder is to ensure that there is sufficient masonry above the hanger to meet the manufacturer's specifications



## An Introduction to VERSA-LAM® Products

VERSA-LAM® is one of the strongest and stiffest engineered wood products approved in the UK.

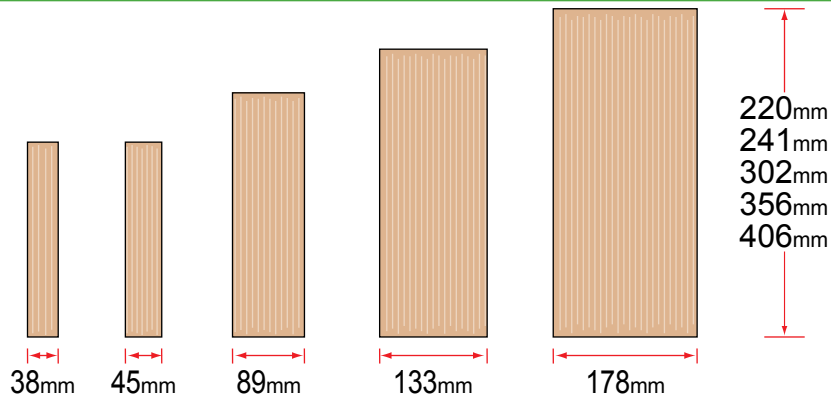

VERSA-LAM® products are excellent as floor and roof framing supports or as lintels for doors, windows and garage doors and columns.

Manufactured with no camber, VERSA-LAM® LVL products provide flatter, quieter floors, and consequently, the builder can expect happier customers with significantly fewer call backs.

## VERSA-LAM® Beam Specifications

### Materials and Manufacture:

VERSA-LAM® LVL comprises laminated Southern Yellow Pine veneers. The veneers are bonded together with waterproof structural adhesives with the grain running parallel. Each veneer is 2550m long, being lap jointed internally and scarf jointed on the face plies. The joints are staggered by at least 125mm.

### Quality Assurance:

VERSA-LAM® is approved for use in the UK by the British Board of Agrément and is manufactured under a factory production control system audited on a monthly basis by a third-party inspection agency.

### Sizes:

Whilst VERSA-LAM® can be manufactured and supplied in billets up to 1.2mx1.2mx20m long, it is typically available in thicknesses of 38, 45, 89, 133 and 178mm, and in depths ranging from 89mm to 508mm. Please check for product availability in the UK.

### Tolerances:

Tolerances in finished dimensions are:

|           |        |
|-----------|--------|
| Thickness | ±1.6mm |
| Width     | ±3.2mm |
| Length    | ±3.2mm |

### Moisture Content:

VERSA-LAM® will arrive on-site with a moisture content of 8% to 10%. In a Service Class 1 environment (as defined in BS5268-2:2002), it will attain an equilibrium moisture content of 10%, whilst in a Service Class 2 environment, it will reach a final equilibrium moisture content of 12% to 14%. In similar environments, solid timber will reach an equilibrium moisture content of 12% and 18%, respectively, having typically been delivered to site at approximately 18% to 24% moisture content.

### Treatment:

VERSA-LAM® is an untreated product with a natural durability sufficient to ensure a minimum design life of 60 years when installed in a Service Class 1 or 2 environment and not subject to mechanical damage or insect attack. Preservative treatment should not be undertaken without consulting Boise Cascade Engineered Wood Products Engineering, as this may affect the structural integrity of the product.



VERSA-LAM® is approved for use under the UK Building Regulations by British Board of Agrément BBA Certificate No. 99/3619.

BBA certification is recognised by:

N.H.B.C.

TRA

UKTFA

Building Control Officers

Building Contractors

VERSA-LAM® Design Properties

VERSA-LAM® is intended for use as structural members such as beams, ties, struts or structural framing (including use in components such as trusses and panels), in Service Class 1 or 2 environments as defined in BS5268-2:2002.

The following design modification factors given in BS5268-2:2002 which can be used for VERSA-LAM® are:

$$k_3, k_4, k_5, k_7, k_{12}, \text{ and } k_{13}.$$

The design modification factor  $k_8$  for load-sharing may also be used, but with a reduced value of 1.04.

For the design of tension members, design stresses should be modified by a length modification factor  $k_L$  as follows:

$$k_L = \left(\frac{2440}{L}\right)^{0.125}$$

Where L = Member length (in mm) with a minimum value = 2440mm.

| Property                                     | Value (N/mm <sup>2</sup> ) |                       |
|--|----------------------------|-----------------------|
|  | Service Class 1            | Service Class 2       |
| Bending parallel to grain:                   |                            |                       |
| as a joist .....                             | 19.0                       | 17.1                  |
| as a plank .....                             | 19.0                       | 17.0                  |
| Tension parallel to grain .....              | 15.0                       | 13.5                  |
| Compression parallel to grain .....          | 19.5                       | 17.5                  |
| Compression perpendicular to grain:          |                            |                       |
| as a joist .....                             | 4.4                        | 4.0                   |
| as a plank .....                             | 2.9                        | 2.6                   |
| Shear parallel to grain:                     |                            |                       |
| as a joist .....                             | 2.0                        | 1.8                   |
| as a plank .....                             | 1.3                        | 1.2                   |
| Modulus of elasticity parallel to grain:     |                            |                       |
| mean .....                                   | 14,000                     | 13,000                |
| minimum .....                                | 14,000                     | 13,000                |
| Modulus of elasticity perpendicular to grain | 700                        | 650                   |
| Modulus rigidity .....                       | 875                        | 812                   |
| Density @ 10% mc .....                       | 630 kg/m <sup>3</sup>      | 630 kg/m <sup>3</sup> |
| @ 15% mc .....                               | 690 kg/m <sup>3</sup>      | 690 kg/m <sup>3</sup> |

Holes and Notches in VERSA-LAM® and VERSA-LAM® Rim

Holes and notches in VERSA-LAM® and VERSA-LAM® Rim should be formed in accordance with the guidelines given for solid timber members in The Building Regulations Approved Document, "Timber Intermediate Floors for Dwellings," as shown below. The diagrams below are intended for use with VERSA-LAM® members that support mainly uniform load. Where the load is not uniform or large isolated point loads exist, contact Boise Cascade Engineered Wood Products Engineering for guidance.

Holes/notches that can be formed in VERSA-LAM® without recourse to structural calculation

For members that are predominantly uniformly loaded (i.e. by a series of point loads of essentially equal magnitude and spacing), the holes or notches shown in figures 1a-1c can be formed without recourse to structural calculation.

**Figure 1a - Elevation on member - Notches on top edge**  
 Notches of depth of 0.125H or 30mm, whichever is lesser, are permitted in this zone

**Figure 1b - Elevation on member - Holes on centreline**  
 Circular holes of diameter 0.25H or 60mm, whichever is lesser, are permitted in this zone

**Figure 1c - Elevation on member - Small holes in centreline**  
 Circular holes of diameter up to 0.1H or 30mm, whichever is the lesser, located on the member's horizontal centreline, can be located at any point along the beam except within 200mm of the beam ends

Minimum spacing between holes/notches =  $\max(3d_{\text{NOTCH}}, 3D_{\text{HOLE}}, 100\text{mm})$

For a design method to calculate large circular holes in VERSA-LAM®, please contact Boise Cascade EWP Engineering on 01420 590078.

## VERSA-LAM® Products — Allowable Nail Spacing

Nailed joints in VERSA-LAM® should be designed using the permissible nail values given in BS 5268-2: 2002 for C27 timber. Nails should be spaced in accordance with the following table.

| Nailing to Narrow Face (Parallel to Glue Lines) |                   |                    |                                     |   |
|---|-------------------|--------------------|-------------------------------------|---|
| Nail Diameter (mm)                              | End Distance (mm) | Edge Distance (mm) | Along Face - Parallel to Grain (mm) | Across Face - Perpendicular to Grain (mm) |
| 3.0   | 60                | 15                 | 60                                  | 15  |
| 3.35  | 67                | 17                 | 67                                  | 17  |
| 3.75  | 75                | 19                 | 75                                  | 19  |
| 4.0   | 80                | 20                 | 80                                  | 20  |

| Nailing to Wide Face (Perpendicular to Glue Lines) |                   |                    |                                     |   |
|--|-------------------|--------------------|-------------------------------------|---|
| Nail Diameter (mm)                                 | End Distance (mm) | Edge Distance (mm) | Along Face - Parallel to Grain (mm) | Across Face - Perpendicular to Grain (mm) |
| 3.0  | 48                | 15                 | 48                                  | 24  |
| 3.35   | 54                | 17                 | 54                                  | 27  |
| 3.75   | 60                | 19                 | 60                                  | 30  |
| 4.0  | 64                | 20                 | 64                                  | 32  |

Nailing Parallel to Glue lines (Narrow Face)

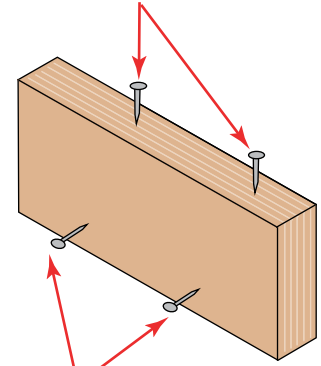

Nailing Perpendicular to Glue lines (Wide Face)

## VERSA-LAM® Products Used as Beams

VERSA-LAM® is ideal for use as a principal load-carrying beam in floor, roof and other timber engineering applications. Maximum allowable long-term uniformly distributed loads are tabulated on page 47 for a range of VERSA-LAM® beam sizes over a range of typical beam spans. These have been derived by application of the design principles contained in BS5268-2:2002, using the VERSA-LAM® property data contained in BBA Certificate No. 99/3619. Maximum allowable loads for other beam sizes, spans or load durations can be developed by using the same design principles by using the BC CALC® design software or contacting Boise Cascade Engineering on 01420 590078.

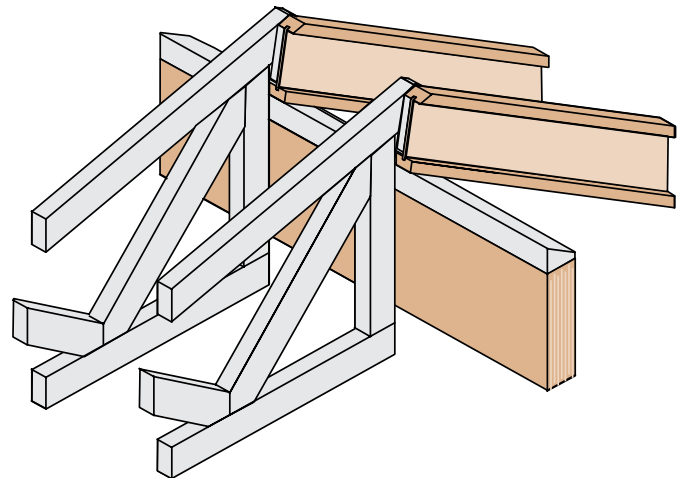

**CERTIFICATE NO. 99/3619**

VERSA-LAM® is approved for use under the UK Building Regulations by BBA Certificate No. 99/3619. It is one of the strongest and stiffest engineered wood products currently approved in the UK.

BBA Certification is recognized by:

NHBC  
UKTFA  
Building Contractors

TRA  
Building Control Officers

## Allowable Loads on VERSA-LAM® Beams

| Beam Span <sup>1</sup> (m) | Maximum Allowable Long-Term Uniformly Distributed Load (kN/m) on VERSA-LAM® Beams in Service Class 1 Conditions <sup>2, 3</sup> |       |        |        |                          |       |        |        |                          |       |        |        |                          |       |        |        |                          |       |        |        |
|----------------------------|---|-------|--------|--------|--------------------------|-------|--------|--------|--------------------------|-------|--------|--------|--------------------------|-------|--------|--------|--------------------------|-------|--------|--------|
|                            | 220mm depth <sup>6</sup>  |       |        |        | 241mm depth <sup>6</sup> |       |        |        | 302mm depth <sup>6</sup> |       |        |        | 356mm depth <sup>6</sup> |       |        |        | 406mm depth <sup>6</sup> |       |        |        |
|                            | 45 mm   | 89 mm | 133 mm | 178 mm | 45 mm                    | 89 mm | 133 mm | 178 mm | 45 mm                    | 89 mm | 133 mm | 178 mm | 45 mm                    | 89 mm | 133 mm | 178 mm | 45 mm                    | 89 mm | 133 mm | 178 mm |
| 3                          | 4.34  | 8.69  | 13.04  | 17.39  | 5.66                     | 11.31 | 17.00  | 22.69  | 10.66                    | 21.33 | 31.99  | 42.66  | 15.42                    | 30.85 | 46.27  | 61.70  | 19.86                    | 39.73 | 59.59  | 76.46  |
| 3.5                        | 2.76  | 5.52  | 8.28   | 11.05  | 3.62                     | 7.24  | 10.86  | 14.49  | 6.89                     | 13.79 | 20.68  | 27.58  | 10.96                    | 21.93 | 32.90  | 43.87  | 14.56                    | 29.12 | 43.68  | 58.25  |
| 4                          | 1.85  | 3.7   | 5.55   | 7.41   | 2.43                     | 4.86  | 7.29   | 9.72   | 4.69                     | 9.38  | 14.07  | 18.76  | 7.52                     | 15.04 | 22.56  | 30.09  | 10.95                    | 21.90 | 32.85  | 43.81  |
| 4.5                        | 1.29  | 2.58  | 3.87   | 5.17   | 1.70                     | 3.41  | 5.12   | 6.83   | 3.31                     | 6.62  | 9.93   | 13.25  | 5.35                     | 10.70 | 16.05  | 21.43  | 7.85                     | 15.30 | 23.55  | 31.41  |
| 5                          | 0.93  | 1.86  | 2.79   | 3.73   | 1.23                     | 2.47  | 3.70   | 4.94   | 2.42                     | 4.84  | 7.26   | 9.68   | 3.93                     | 7.87  | 11.79  | 15.74  | 5.80                     | 11.60 | 17.40  | 23.20  |
| 5.5                        | 0.68  | 1.37  | 2.06   | 2.75   | 0.91                     | 1.83  | 2.73   | 3.66   | 1.81                     | 3.62  | 5.43   | 7.24   | 2.96                     | 5.92  | 8.88   | 11.85  | 4.39                     | 8.78  | 13.17  | 17.56  |
| 6                          | 0.51  | 1.03  | 1.55   | 2.07   | 0.69                     | 1.38  | 2.07   | 2.77   | 1.38                     | 2.77  | 4.15   | 5.54   | 2.28                     | 4.56  | 6.84   | 9.13   | 3.39                     | 6.78  | 10.17  | 13.56  |
| 6.5                        | 0.39  | 0.79  | 1.18   | 1.58   | 0.53                     | 1.06  | 1.59   | 2.12   | 1.07                     | 2.15  | 3.22   | 4.30   | 1.78                     | 3.56  | 5.34   | 7.13   | 2.66                     | 5.33  | 7.99   | 10.66  |
| 7                          | 0.30  | 0.61  | 0.91   | 1.22   | 0.41                     | 0.82  | 1.23   | 1.65   | 0.84                     | 1.69  | 2.54   | 3.39   | 1.41                     | 2.83  | 4.23   | 5.66   | 2.12                     | 4.25  | 6.37   | 8.50   |
| 7.5                        | 0.23  | 0.47  | 0.71   | 0.95   | 0.32                     | 0.64  | 0.96   | 1.29   | 0.67                     | 1.35  | 2.02   | 2.70   | 1.13                     | 2.27  | 3.40   | 4.54   | 1.71                     | 3.43  | 5.14   | 6.86   |
| 8                          | 0.18  | 0.37  | 0.55   | 0.74   | 0.25                     | 0.51  | 0.76   | 1.02   | 0.54                     | 1.08  | 1.63   | 2.17   | 0.92                     | 1.84  | 2.77   | 3.69   | 1.40                     | 2.80  | 4.20   | 5.60   |
| 8.5                        | 0.14  | 0.29  | 0.43   | 0.58   | 0.20                     | 0.40  | 0.60   | 0.80   | 0.44                     | 0.88  | 1.32   | 1.76   | 0.75                     | 1.51  | 2.26   | 3.02   | 1.15                     | 2.30  | 3.45   | 4.61   |

**Notes :**

- <sup>1</sup> Beam spans quoted are 'engineering spans' measured between centres of bearing points.
- <sup>2</sup> Maximum loads tabulated are for long-term loading conditions including an allowance for the beam self weight.
- <sup>3</sup> Tabulated loads are based on a deflection limit of 0.3% of the beam span. The designer should consider the need for improved deflection criteria for principal members, or for aesthetics.
- <sup>7</sup> Thicknesses other than those shown may be available by special order.

- <sup>4</sup> VERSA-LAM® beams require effective lateral restraint to the compression edge of 600 mm maximum spacing. VERSA-LAM® beams require effective lateral restraint at all supports.
- <sup>5</sup> For allowable loads on VERSA-LAM® beams for use in Service Class 2 conditions, contact Boise Cascade Engineered Wood Products Engineering.
- <sup>6</sup> The depths shown are for indicative purposes only. Other depths between 89-508mm are available. Consult Boise Cascade Engineered Wood Products Engineering for maximum loads available for other depths.



## VERSA-LAM® Beams Used as Columns

The same properties that make VERSA-LAM® perfect for beam applications also make them ideal for columns. In VERSA-LAM® columns, you will find none of the deep checks, cracks or twists that can plague solid timber columns.

### VERSA-LAM® Column Table

| Length<br>(m) | Allowable Axial Load (kN)<br>Long-Term Load Duration |          |          |           |           |           |
|---------------|--|----------|----------|-----------|-----------|-----------|
|               | 89 x 89  | 89 x 133 | 89 x 178 | 133 x 133 | 133 x 178 | 178 x 178 |
| 1.2           | 93.68  |          |          |           |           |           |
| 1.5           | 79.95  | 119.48   |          |           |           |           |
| 1.8           | 67.60  | 101.02   | 135.20   |           |           |           |
| 2.1           | 57.00  | 85.18    | 114.00   | 187.96    |           |           |
| 2.4           | 48.19  | 72.02    | 96.39    | 168.39    | 225.36    |           |
| 2.7           | 40.99  | 61.25    | 81.98    | 150.38    | 201.26    |           |
| 3.0           | 35.12  | 52.49    | 70.25    | 134.16    | 179.55    |           |
| 3.3           | 30.34  | 45.34    | 60.68    | 119.75    | 160.27    |           |
| 3.6           | 26.42  | 39.48    | 52.84    | 107.09    | 143.32    |           |
| 3.9           | 23.18  | 34.64    | 46.36    | 96.03     | 128.52    |           |
| 4.2           | 20.48  | 30.61    | 40.96    | 86.39     | 115.62    | 228.01    |
| 4.5           | 18.21  | 27.22    | 36.43    | 77.99     | 104.38    | 209.53    |
| 4.8           |  | 24.35    | 32.59    | 70.67     | 94.58     | 192.77    |
| 5.1           |  |          | 29.32    | 64.26     | 86.00     | 177.62    |
| 5.4           |  |          |          | 58.64     | 78.48     | 163.95    |
| 5.7           |  |          |          | 53.69     | 71.86     | 151.62    |
| 6.0           |  |          |          | 49.32     | 66.01     | 140.49    |
| 6.3           |  |          |          | 45.45     | 60.83     | 130.45    |
| 6.6           |  |          |          | 42.00     | 56.21     | 121.36    |
| 6.9           |  |          |          |           | 52.09     | 113.14    |
| 7.2           |  |          |          |           |           | 105.67    |

#### Notes:

- Table assumes that the column is braced at column ends only.
- Effective column length is equal to actual column length.
- Allowable loads are based on solid, one piece column members used in Service Class 1 conditions.
- Allowable loads relate to axially loaded columns only (no bending) and are based on the provisions given in BS5268-2:2002. The modification factor  $K_{12}$  has been calculated using an eccentricity factor of 0.01 of the slenderness ratio, as used in the equation in Annex B of BS5268-2:2002.

## VERSA-LAM® Common Framing Details

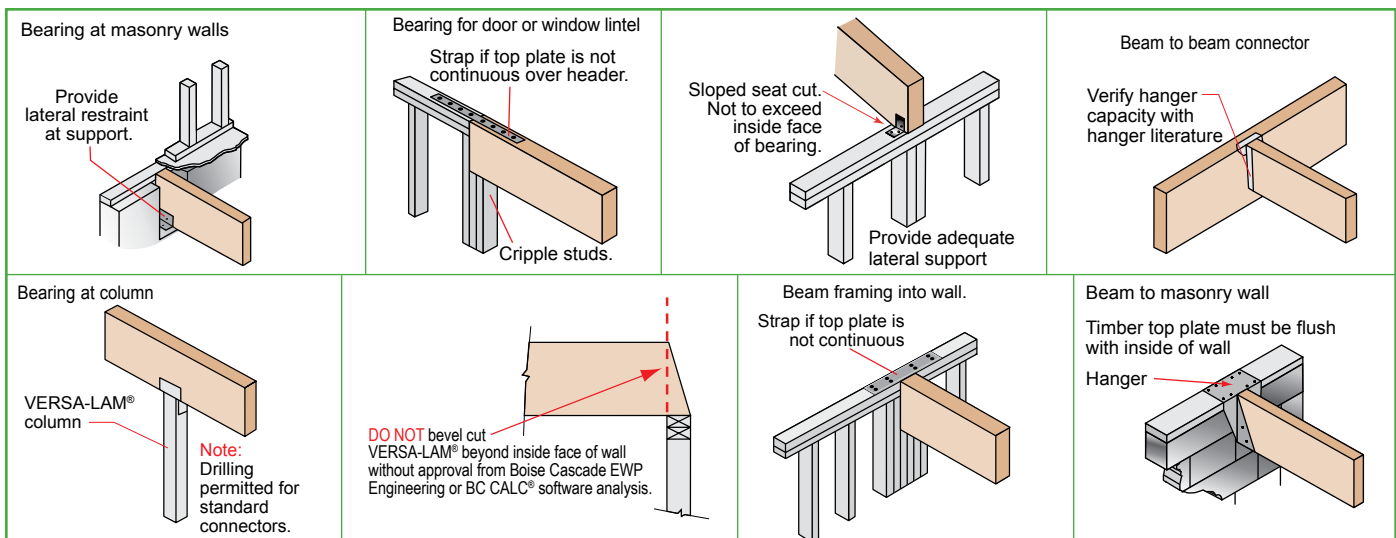

#### VERSA-LAM® Installation Notes

- Adequate bearing shall be provided.
- VERSA-LAM® beams are intended for use in service class 1 and 2 environments and should be kept as dry as possible during construction.
- Continuous lateral restraint required to compression edge, see note 4 on page 47.

## Multiple Member Connectors

| VERSA-LAM® Ply Thickness (mm) | No. of Plies | Finished Thickness (mm) | Maximum Long Term Uniform Load (kN/m) |         |         |         |                              |         |         |         |
|-------------------------------|--------------|-------------------------|---------------------------------------|---------|---------|---------|------------------------------|---------|---------|---------|
|                               |              |                         | 3.35mm x 75mm Nails                   |         |         |         | Simpson Strong-Tie SDS Screw |         |         |         |
|                               |              |                         | 150 c/c                               | 300 c/c | 450 c/c | 600 c/c | 150 c/c                      | 300 c/c | 450 c/c | 600 c/c |
| 38                            | 2            | 76mm                    | 12.32                                 | 6.16    | 4.11    | 3.08    | 17.13                        | 8.56    | 5.71    | 4.28    |
|                               | 3            | 114mm                   | 4.62                                  | 2.31    | 1.54    | 1.15    | 6.42                         | 3.21    | 2.14    | 1.60    |
| 45                            | 2            | 90mm                    | 11.66                                 | 5.83    | 3.88    | 2.91    | 17.56                        | 8.78    | 5.85    | 4.39    |
|                               | 3            | 135mm                   | 4.37                                  | 2.18    | 1.45    | 1.09    | 6.58                         | 3.29    | 2.19    | 1.64    |

### VERSA-LAM® Nailing Details

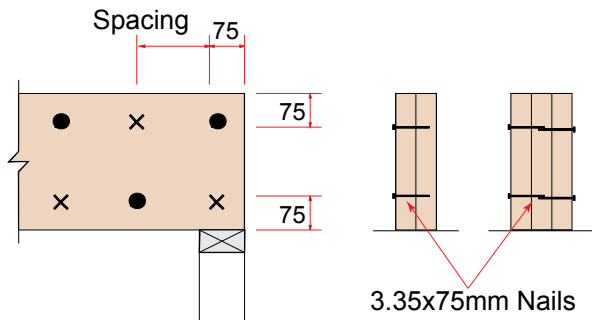

- Denotes nails from near face
- × Denotes nails from far face (2 Ply VERSA-LAM® Nail from 1 side only)

### Simpson Strong-Tie SDS Screw Detail

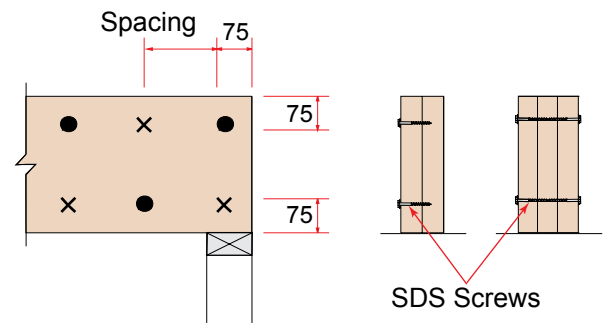

- Denotes screws from near face
- × Denotes screws from far face (2 Ply VERSA-LAM® Screw from 1 side only)

| VERSA-LAM® Ply Thickness (mm) | No. of Plies | Finished Thickness (mm) | Maximum Long Term Uniform Load (kN/m) |         |         |           |         |         |
|-------------------------------|--------------|-------------------------|---------------------------------------|---------|---------|-----------|---------|---------|
|                               |              |                         | M12 Bolts                             |         |         | M16 Bolts |         |         |
|                               |              |                         | 300 c/c                               | 450 c/c | 600 c/c | 300 c/c   | 450 c/c | 600 c/c |
| 38                            | 2            | 76                      | 25.74                                 | 17.16   | 12.87   | 31.53     | 21.02   | 15.76   |
|                               | 3            | 114                     | 19.31                                 | 12.87   | 9.65    | 23.64     | 15.76   | 11.82   |
| 45                            | 2            | 90                      | 29.81                                 | 19.87   | 14.90   | 36.51     | 24.34   | 18.25   |
|                               | 3            | 135                     | 22.35                                 | 14.90   | 11.17   | 27.38     | 18.25   | 13.69   |
| 89                            | 2            | 178                     | 48.63                                 | 32.42   | 24.32   | 69.82     | 46.55   | 34.91   |
|                               | 3            | 267                     | 36.47                                 | 24.31   | 18.23   | 52.37     | 34.91   | 26.18   |
| 133                           | 2            | 266                     | 48.63                                 | 32.42   | 24.31   | 82.85     | 55.23   | 41.42   |

### VERSA-LAM® Bolting Details

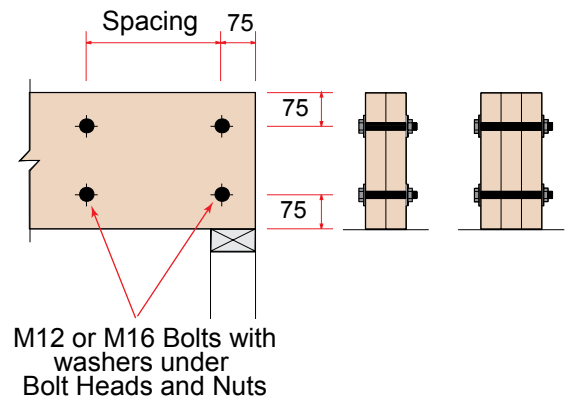

M12 or M16 Bolts with washers under Bolt Heads and Nuts

#### Notes :

- The tabulated maximum loads are calculated using the permissible nail and bolt values given in BS 5268-2: 2002 for C27 grade timber, assuming the loading is applied on one side of the beam (via hangers).
- The tabulated maximum long-term loads for nail fixings can be multiplied by load Duration Factor  $k_{48}$  (1.12 for medium-term loading and 1.25 for short-term loading).
- Required washer size for M12 and M16 bolts are minimum 36mm diameter x 3.0mm thick and 48mm diameter x 4.0mm thick, respectively.
- The above details are suitable only for VERSA-LAM® depths of 241mm and deeper.
- Do not use bolts as connections where either the Moment, Bearing or Shear stress values are in excess of 85% of the permissible values.
- Refer to Boise Cascade Engineered Wood Products Engineering for fixing details outside those tabulated above.

## VERSA-LAM® Beams Used as Rim Material

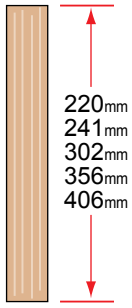

VERSA-LAM®

The high strength properties enjoyed by VERSA-LAM® make it an ideal rim joist material. This is necessary in timber frame construction to transmit vertical loads across the floor zone between external loadbearing walls.

VERSA-LAM® is produced in 38mm thickness with depths matching the BCI® Joist range.

For higher load transfer applications, 45mm wide or even 89mm wide VERSA-LAM® can be used as a rim.

For lower load transfer applications, 32mm wide or 38mm wide VERSA-STRAND® can provide a very cost-effective alternative.

Maximum long term capacities for each of these products are detailed below:



## VERSA-LAM® Products Used as Rim Joists / Bearers

| <b>Maximum Long-Term Load Subject to<br/>Uniform Compression Perpendicular to Grain<br/>(Service Classes 1 and 2)</b> |                                      |
|---|--------------------------------------|
| Product   | Maximum Load Per<br>Metre Run (kN/m) |
| 32mm wide VERSA-STRAND®   | 49.6                                 |
| 38mm wide VERSA-STRAND®<br>38mm wide VERSA-LAM®   | 59.0                                 |
| 45mm wide VERSA-LAM®  | 69.8                                 |
| 89mm wide VERSA-LAM®  | 137.8                                |

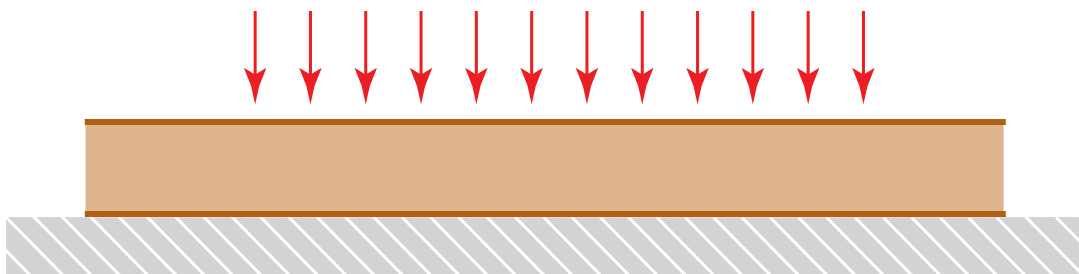

## Concentrated Load Capacities of Boise Cascade Rim Products

In platform timber frame construction, point loads (e.g. from heavily loaded studs) are transferred between storeys through the floor zone on their way to the foundation. They are first imposed on the flooring layer, before being transferred through the rim material and then outwards into the timber frame panel below. The concentrated load spreads out as it passes through the rim construction, and then concentrates again as it enters the studs below.

Compression stresses induced at each interface therefore need to be checked against their maximum permissible values in each of the materials, before the limiting concentrated load capacity of the construction can be determined.

The figures on the right illustrate the load distribution path assumed in calculating the stresses induced at each material interface, and the tables below provide the maximum point load that can therefore be sustained at each interface.

It can be seen that in the majority of cases, the point load capacity of rim constructions incorporating Boise Cascade engineered wood products are dictated by the compression capacity of the flooring material to withstand such concentrated loads, rather than the rim material itself.

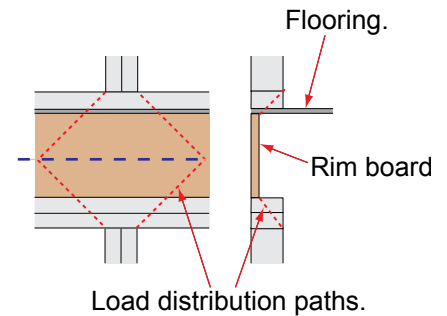

| 32mm VERSA-STRAND®                      |             |       |       |        |              |       |        |              |       |        |              |       |
|---|-------------|-------|-------|--------|--------------|-------|--------|--------------|-------|--------|--------------|-------|
| Cripple Stud Thickness (mm) x 89mm wide |             |       |       |        |              |       |        |              |       |        |              |       |
| Flooring Thickness (mm)                 | 38          |       |       | 2 x 38 |              |       | 3 x 38 |              |       | 4 x 38 |              |       |
|   | C           | F     | R     | C      | F            | R     | C      | F            | R     | C      | F            | R     |
| 15                                      | <b>7.10</b> | 9.21  | 10.14 | 14.21  | <b>11.65</b> | 12.81 | 21.32  | <b>14.08</b> | 15.49 | 28.42  | <b>16.51</b> | 18.16 |
| 18                                      | <b>7.10</b> | 9.60  | 10.56 | 14.21  | <b>12.03</b> | 13.24 | 21.32  | <b>14.46</b> | 15.91 | 28.42  | <b>16.90</b> | 18.59 |
| 22                                      | <b>7.35</b> | 10.11 | 11.12 | 14.71  | <b>12.54</b> | 13.80 | 22.07  | <b>14.98</b> | 16.47 | 29.43  | <b>17.41</b> | 19.15 |

| 38mm VERSA-STRAND® or 38mm VERSA-LAM®   |             |       |       |              |              |       |        |              |       |        |              |       |
|---|-------------|-------|-------|--------------|--------------|-------|--------|--------------|-------|--------|--------------|-------|
| Cripple Stud Thickness (mm) x 89mm wide |             |       |       |              |              |       |        |              |       |        |              |       |
| Flooring Thickness (mm)                 | 38          |       |       | 2 x 38       |              |       | 3 x 38 |              |       | 4 x 38 |              |       |
|   | C           | F     | R     | C            | F            | R     | C      | F            | R     | C      | F            | R     |
| 15                                      | <b>7.44</b> | 10.94 | 12.04 | 14.88        | <b>13.83</b> | 15.22 | 22.32  | <b>16.72</b> | 18.39 | 29.76  | <b>19.61</b> | 21.57 |
| 18                                      | <b>7.44</b> | 11.40 | 12.54 | 14.88        | <b>14.29</b> | 15.72 | 22.32  | <b>17.18</b> | 18.89 | 29.76  | <b>20.06</b> | 22.07 |
| 22                                      | <b>7.44</b> | 12.01 | 13.21 | <b>14.88</b> | 14.90        | 16.39 | 22.32  | <b>17.78</b> | 19.56 | 29.76  | <b>20.67</b> | 22.74 |

| 45mm VERSA-LAM®                         |             |       |       |              |       |       |        |              |       |        |              |       |
|---|-------------|-------|-------|--------------|-------|-------|--------|--------------|-------|--------|--------------|-------|
| Cripple Stud Thickness (mm) x 89mm wide |             |       |       |              |       |       |        |              |       |        |              |       |
| Flooring Thickness (mm)                 | 38          |       |       | 2 x 38       |       |       | 3 x 38 |              |       | 4 x 38 |              |       |
|   | C           | F     | R     | C            | F     | R     | C      | F            | R     | C      | F            | R     |
| 15                                      | <b>7.44</b> | 12.96 | 14.26 | <b>14.88</b> | 16.38 | 18.02 | 22.32  | <b>19.80</b> | 21.78 | 29.76  | <b>23.22</b> | 25.54 |
| 18                                      | <b>7.44</b> | 13.50 | 14.85 | <b>14.88</b> | 16.92 | 18.61 | 22.32  | <b>20.34</b> | 22.37 | 29.76  | <b>23.76</b> | 26.14 |
| 22                                      | <b>7.44</b> | 14.22 | 15.64 | <b>14.88</b> | 17.64 | 19.40 | 22.32  | <b>21.06</b> | 23.17 | 29.76  | <b>24.48</b> | 26.93 |

C denotes maximum capacity of C16 Timber Frame Cripple Stud / Plate.  
 F denotes maximum capacity of 15mm OSB and 18mm or 22mm Chipboard flooring.  
 R denotes maximum capacity of Rim Material.

**Values in bold colour are the limiting capacities.**

## BCI® Joists in Timber Frame Wall Panels

Properties such as strength, stiffness, straightness and light-weight that make BCI® Joists excellent as floor joists also make them ideal for use as studs in timber frame wall panels.

In the wake of Government reports such as Latham's 'Constructing the Team' and Egan's 'Rethinking Construction', developers and designers are increasingly being encouraged to look for more effective methods of building using Modern Methods of Construction (MMC) to reduce build costs, improve construction quality and sustainability and reduce whole life costs whilst anticipating likely future changes in thermal regulations aimed at reducing CO<sub>2</sub> emissions.

BCI® Joist wall panels offer an innovative yet simple option to developers as they seek to meet the above aims. Incorporating BCI® Joist studs into a project provides a cost effective way of meeting and exceeding the current thermal insulation requirements whilst eliminating any worries of distortion or shrinkage in the studs. A typical BCI® Joist wall stud panel provides at least 200mm of internal space and when filled with conventional insulation quilt will achieve a U value of about 0.20 W/m<sup>2</sup>K, yet the wall panel will weigh no more than a conventional solid timber wall panel of 89mm thickness.

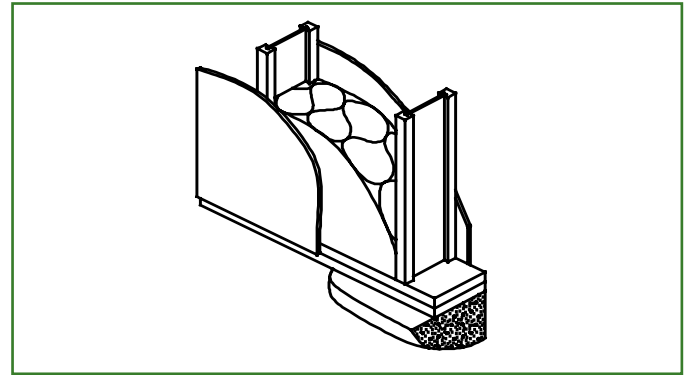

The installation of services within a BCI® Joist wall panel is easily achieved by using either the pre-formed knockout holes in the web, or additional holes in the OSB web formed to accommodate larger services. These are far more easily formed than drilling through solid timber studs and BCI® Joists are much more tolerant to the creation of such holes.

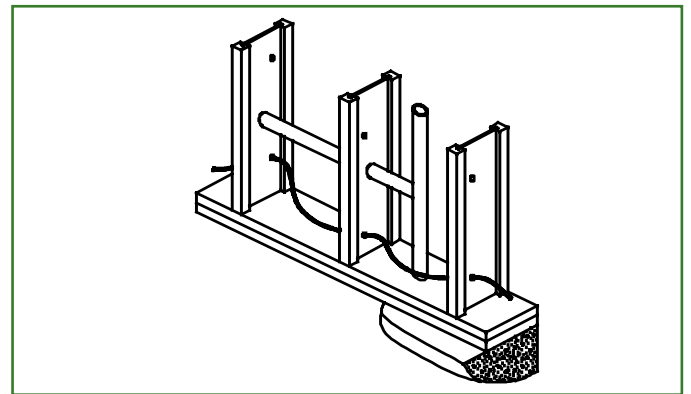

Alternatively, an internal service void can be easily incorporated within the BCI® Joist wall panel as shown below right, thereby allowing the easy routing of services and even the opportunity to install services in the factory as part of a pre-completed panel using the latest MMC.

The design and detailing of wall panels incorporating BCI® Joists will be similar to conventional timber frame construction except that the specific design of the BCI® Joist wall studs will be carried out using a method developed by Boise Cascade. Overall building stability is achieved by means of conventional sheathing material such as OSB or ply.

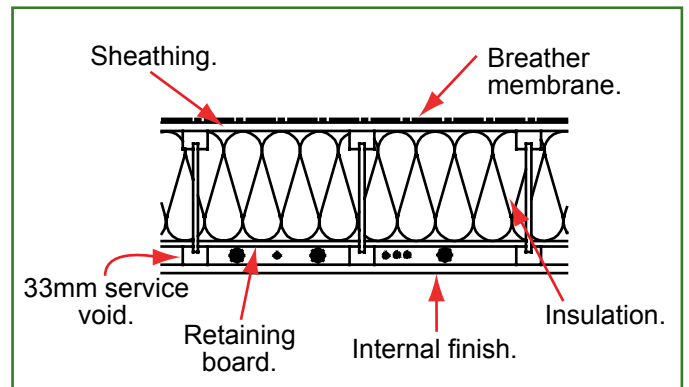



At the heart of the SIMPLE FRAMING SYSTEM® lies Boise Cascade's innovative range of engineered wood products. However, other components are often required to construct effective floor and roof framing solutions.

Boise Cascade enjoys excellent technical links with a number of leading manufacturers, conducting ongoing research and development with its supply partners to further the idea of continuous process improvement.



## Cullen Building Products Limited

1 Wheatstone Place  
Southfield Industrial Estate  
Glenrothes  
Fife KY6 2SW

Tel 01592 771132

Fax 01592 771182

Website  
[www.itw-industry.com/cullen-bp.htm](http://www.itw-industry.com/cullen-bp.htm)

These include the metalwork connector manufacturers Cullen Building Products Limited and Simpson Strong-Tie. Each company produces comprehensive technical data directly relating to our BCI® Joist and VERSA-LAM® products. This data can be obtained via their website addresses or by contacting them directly. Details are below.



## Simpson Strong-Tie

Winchester Road  
Cardinal Point  
Tamworth  
Staffordshire B78 3HG

Tel 01827 255600

Fax 01827 255616

Website  
[www.strongtie.co.uk](http://www.strongtie.co.uk)

## Correct fixing on hangers

|   |  |  |  |                                   |                             |
|---|--|--|--|-----------------------------------|-----------------------------|
| <p><b>Toe nailing causes squeaks and improper hanger installations. Do not toe nail I-joists prior to installing either top flange or face mount hangers.</b></p> | <p><b>Hanger Over-Spread</b><br/>If the hanger is over-spread, it can raise the I-joist above the header and may cause uneven surfaces and squeaky floors.</p> | <p><b>Hanger Not Plumb</b><br/>A hanger "kicked out" from the header can cause uneven surfaces and squeaky floors.</p>                                     | <p><b>No Web Stiffener Results in Rotation</b><br/>Hanger side flange is below the joist top flange. No web stiffener results in rotation, unless restrained by other means.</p> | <p><b>Nail at Wrong Angle</b></p> | <p><b>Nail Too Long</b></p> |
| <p><b>No Web Stiffener Installed</b><br/>Hanger side flange supports joist top flange.</p>  | <p><b>Web Stiffener Required</b><br/>Hanger side flange should be at least 60% of joist depth or potential joist rotation must be addressed.</p>               | <p><b>Rotation Resistance</b><br/>If non-skewed hanger side flange is less than 60% of joist depth, attach staggered framing anchors above the hanger.</p> | <p><b>Correct Nailing</b></p>  |                                   |                             |

- Backer Block** . . . . . OSB or plywood blocks used as a backing plate where hangers are connected onto an I-Joist at 90° (see *detail F11*).
- BCI® Joist** . . . . . An I-Joist product produced exclusively by Boise Cascade using VERSA-LAM® LVL as the flange material and OSB as the web material (see *page 6*).
- Beams** . . . . . Structural members which act individually to support applied loads.
- Cantilever** . . . . . That part of a structural member that extends beyond the supporting superstructure (see *page 25-26*).
- Concentrated Load** . . . . . Localised load applied at a specific location.
- Dead Load** . . . . . Permanent loads applied from the materials used in the building.
- Deflection** . . . . . The deformation of a member due to loads applied to it.
- Engineering Span** . . . . . Span measured between centres of bearing points – used as the basis for structural calculations on beams/joists (see *page 14*).
- EWP** . . . . . Engineered Wood Products – Reconstituted timber products which use the principle of defect dispersal to improve strength and stability, and reduce the inherent variability of wood.
- Filler Block** . . . . . OSB, timber or plywood packs fitted between the webs of multi-ply I-Joists to enable them to be rigidly fixed together to form a compound element (see *detail F12*).
- Flange** . . . . . Top and bottom parts of an I-Joist which provide the majority of bending resistance when used as a beam.
- Floor Performance** . . . . . The "feel" of a floor which can be affected by many factors (see *page 12*).
- Framing Connectors** . . . . . Metal hangers, clips or straps used to connect structural timber elements together, or to the supporting superstructure (see *page 53*).
- Header** . . . . . See *Trimmer*.
- Imposed Load** . . . . . Loads arising from the occupancy and use of the building.
- Joists** . . . . . Structural members placed at regular centres to support floor loadings.
- Knockouts** . . . . . 38mm round partially pre-stamped areas within the webs of BCI® Joists, which can be used for the routing of services (see *page 28*).
- Live Load** . . . . . See *Imposed Load*.
- Load Sharing** . . . . . An assembly of at least 4-No structural members spaced at centres no greater than 610mm and tied together by means of decking such that they act together to support a common load.
- Long-Term Loading** . . . . . Loads assumed to act on the structure for a continuous period of 50 years or more (e.g. dead loads plus permanent imposed loads).
- LVL** . . . . . Laminated Veneer Lumber - a reconstituted timber product consisting of thin timber veneers glued together with their grain laying parallel to each other to form a solid beam.
- Medium-Term Loading** . . . . . Loads assumed to act for an accumulated period of no more than 6 months throughout the life of the structure (e.g. snow loadings).
- Nogging** . . . . . Timber battens fixed between joists to provide fixing points for other elements (e.g. plasterboard, restraint straps).
- OSB** . . . . . Orientated Strand Board – a reconstituted timber board material formed by gluing flakes of timber together with their orientation primarily parallel to the board direction.
- Perimeter Nogging** . . . . . Timber battens fixed to the external walls between joist ends to facilitate floor board fixing.
- Rafters** . . . . . Structural members spaced at regular centres to support roof loadings.
- Rim Joist** . . . . . A perimeter beam laid around the external load-bearing walls in timber frame construction to provide lateral stability and act as a closure for the purposes of fire/moisture resistance as well as assisting in transferring vertical loads between upper and lower storey's (see *details F1-F5*).
- Service Holes** . . . . . Site drilled/cut areas through webs of I-Joists which allow free passage of service pipes/conduit (see *page 28*).
- Short-Term Loading** . . . . . Loads assumed to act for a continuous period of no more than 1-week throughout the life of the structure (e.g. man load).
- Squash Blocks** . . . . . Timber blocks located beneath high concentrated loads, with their end grain vertical, which transfer these loads directly between upper and lower storey's, thus obviating the need for joists to perform this function (see *detail F8a*).
- Stud Wall Nogging** . . . . . Timber battens placed between joists beneath non load-bearing walls to provide additional support and facilitate fixing of these walls (see *detail F7*).
- SVP** . . . . . Soil Vent Pipe.
- Temporary Bracing** . . . . . An arrangement of timber blocking together with diagonal and longitudinal timber members, used to provide temporary lateral restraint to structural floor or roof systems during construction. The principle employed is first to create a laterally "stiff bay" by means of blocking and diagonal members, and then to brace all other joists/rafters back to that "bay" via longitudinal members (see *page 27*).
- Trimmer** . . . . . Framing member spanning perpendicular to the main floor joists around openings (see *page 25*).
- Trimming Joist** . . . . . Joists either side of a structural opening running parallel to the main floor joists, onto which Header Joists are supported (see *page 25*).
- Uniform Loads** . . . . . Load applied uniformly over a given length or area.
- VERSA-LAM®** . . . . . An LVL product produced exclusively by Boise Cascade using Southern Pine (see *page 44*).
- Web** . . . . . Central portion of an I-Joist providing the majority of shear resistance when used as a beam.
- Web Stiffener** . . . . . OSB or plywood blocks fixed to the webs of I-Joists to improve web shear or joist bearing resistance at bearing positions or points of high concentrated load, or used as a web packer to facilitate the fixing of certain types of hangers (see *detail F10*).
- Z-clips** . . . . . Folded metal clips fixed to I-Joist flanges to support stud wall noggings (see *detail F7*).

## Site Storage

• Protect BCI® Joists from the weather.

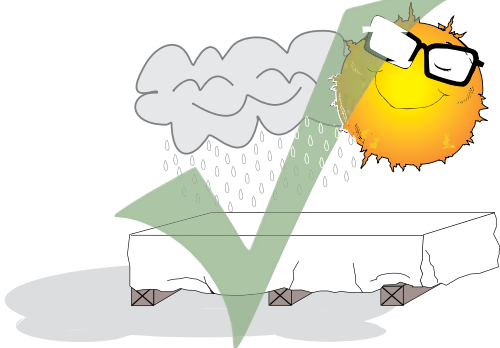

Use 150mm min. bearers to keep BCI Joists level and clear of the ground (approx. 3.0m centres).

• Leave BCI® Joists banded together until ready to install.

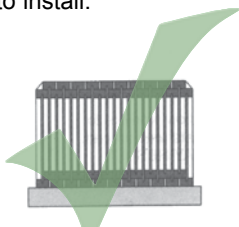

Store BCI® Joists vertically.



Do not store flat.

## Site Handling



Unload from lorry carefully using appropriate equipment.



Do not lift BCI® Joists by top flange.

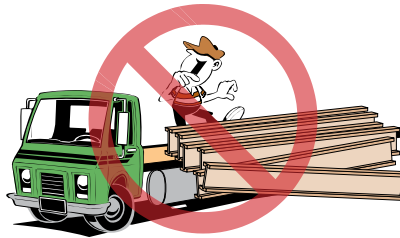

Do not drop BCI Joists from height.



Avoid lifting BCI® Joists horizontally.

Contractors should be aware of their health and safety responsibilities under the Construction (Design & Management) Regulations 1994



## Warning

## The following Uses Are Not Allowed

**DO NOT** cut notches or holes that are not in accordance with this Technical Guide.

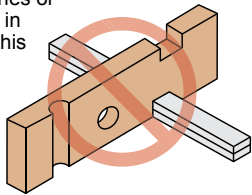

**DO NOT** cut beyond inside edge of bearing.

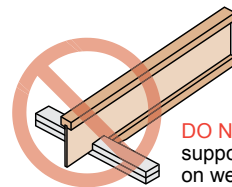
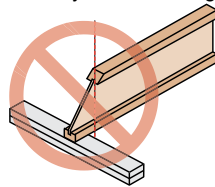

**DO NOT** support joist on web.

**DO NOT** cut holes too close to supports or to each other.

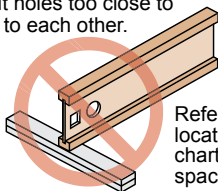

Refer to hole location and sizing chart for size and spacing.

**DO NOT** nail closer than 38mm from end of joist.

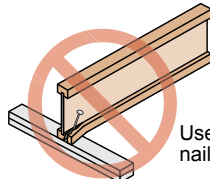

Use 3.35x65mm nails.

**DO NOT** cut or notch flange.

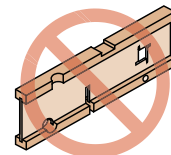

See roof and floor details for allowed cutting of flange.

**DO NOT** walk on joist until proper bracing is in place.

**DO NOT** load joist beyond design capacity.

**DO NOT** stack building materials on unbraced joists.

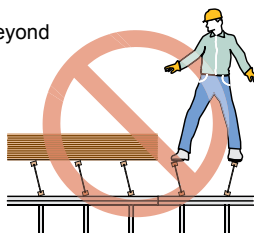

**DO NOT** install tongue of floor sheathing flush with VERSA-LAM®. Trim tongue flush with rim.

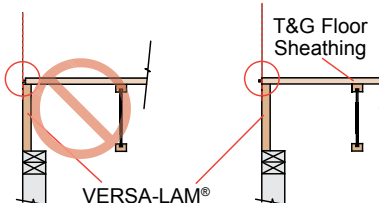

Trim tongue of sheathing regardless of rimboard thickness.

**DO NOT** hammer on web unless removing knockout holes.

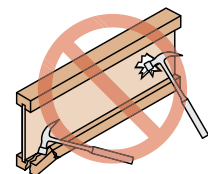

**DO NOT** hammer on flange.



**Boise Cascade**  
*Engineered Wood Products*

Boise Cascade Engineered Wood Products  
3 The Long Barn  
Brynkinalt Business Centre  
Chirk Wrexham LL14 5NS

T 01691 770530 F 01691 770535

[boise.ewp.eu@bc.com](mailto:boise.ewp.eu@bc.com) - Email

[www.BC.com/eu](http://www.BC.com/eu) - Website

For specific engineering advice, please contact  
Boise Cascade EWP Engineering on 01420 590078

**Simple  
Framing  
System®**

Available from